

DESIGN, FABRICATION AND PERFORMANCE STUDY OF A SOLAR WATER DESALINATION (SINGLE SLOPE STILL)

Submitted By

Aakifah Yainkain Kamara 200011157

Momodou Bah 220032108

Alimamy Jarjusey 220032109

Supervised By

Prof. Dr. Md. Rezwanul Karim

**A thesis submitted in partial fulfillment of the requirement for the degree of Bachelor of
Science in Mechanical Engineering and Bachelor of Science in Technical Education
(with specialization in Mechanical Engineering)**



Department of Mechanical and Production Engineering (MPE)

Islamic University of Technology (IUT)

October 2025

Candidate's Declaration

This is to certify that the work presented in this project titled, “DESIGN, FABRICATION AND PERFORMANCE STUDY OF A SOLAR WATER DESALINATION (SINGLE SLOPE STILL)” is the outcome of the investigation and work carried out by us under the supervision of Prof. Dr. Md. Rezwanul Karim, MPE Department, IUT.

It is also declared that neither this thesis nor any part of it has been submitted elsewhere for the award of any degree or diploma.

Aakifah Yainkain Kamara 200011157

Momodou Bah 220032108

Alimamy Jarjusey 220032109

Recommendation of the project Supervisors

The Project titled “**DESIGN, FABRICATION AND PERFORMANCE STUDY OF A SOLAR WATER DESALINATION (SINGLE SLOPE STILL)**” submitted by **Aakifah Yainkain Kamara 200011157, Momodou Bah 220032108** and **Alimamy Jarjusey 220032109** has been accepted as satisfactory in partial fulfillment of the requirements for the degree of B.Sc. in Mechanical Engineering and B.Sc. in Technical Education on 29 September 2025.

Supervised By

Dr. Md. Rezwanul Karim

Professor

Department of Mechanical and Production Engineering

Islamic University of Technology (IUT)

Board Bazar, Gazipur-1704, Bangladesh.

CO-PO Mapping of ME 4800 -Thesis and Project

COs	Course Outcomes (CO) Statement	(PO)	Addressed by	
CO1	<u>Discover and Locate</u> research problems and illustrate them via figures/tables or projections/ideas through field visit and literature review and <u>determine/Setting</u> aim and objectives of the project/work/research in specific, measurable, achievable, realistic and timeframe manner.	PO2 Problem analysis	Thesis Book	
			Performance by research	
			Presentation and soft skill	
CO2	<u>Design</u> research solutions of the problems towards achieving the objectives and its application. Design systems, components or processes that meets related needs in the field of mechanical engineering	PO3 Design/development of solutions	Thesis Book	
			Performance by research	
			Presentation and soft skill	
CO3	<u>Review, debate, compare</u> and <u>contrast</u> the relevant literature contents. Relevance of this research/study. Methods, tools, and techniques used by past researchers and justification of use of them in this work.	PO4 Investigation	Thesis Book	
			Performance by research	
			Presentation and soft skill	
CO4	<u>Analyse</u> data and <u>exhibit</u> results using tables, diagrams, graphs with their interpretation. <u>Investigate</u> the designed solutions to solve the problems through case study/survey study/experimentation/simulation using modern tools and techniques.	PO5 Modern tool usage	Thesis Book	
			Performance by research	
			Presentation and soft skill	
CO5	<u>Apply</u> moral values and research/professional ethics throughout the work, and <u>justify</u> genuine referencing on sources, and demonstration of own contribution.	PO8 Ethics	Thesis Book	
			Performance by research	
			Presentation and soft skill	
CO6	<u>Perform</u> own self and <u>manage</u> group activities from the beginning to the end of the research/work as a quality work.	PO9 Individual work and teamwork	Thesis Book	
			Performance by research	
			Presentation and soft skill	
CO7	<u>Compile and arrange</u> the work outputs, write the report/thesis, a sample journal paper, and present the work to wider audience using modern communication tools and techniques.	PO10 Communication	Thesis Book	
			Performance by research	
			Presentation and soft skill	
CO8	<u>Recognize</u> the necessity of life-long learning in career development in dynamic real-world situations from the experience of completing this project.	PO12 Life-long learning	Thesis Book	
			Performance by research	
			Presentation and soft skill	

1. Aakifah Yainkain Kamara 200011157
2. Momodou Bah 220032108
3. Alimamy Jarjusey 220032109

Supervised By
Prof. Dr. Md. Rezwanul Karim

K-P-A Mapping of ME 4800 -Theis and Project

COs	POs	Related Ks								Related Ps							Related As				
		K1	K2	K3	K4	K5	K6	K7	K8	P1	P2	P3	P4	P5	P6	P7	A1	A2	A3	A4	A5
CO1	PO2	√	√	√	√					√											
CO2	PO3					√				√	√	√				√	√	√	√		
CO3	PO4								√	√	√	√				√	√				
CO4	PO5						√			√				√							
CO5	PO8							√													
CO6	PO9																				
CO7	PO10																				
CO8	PO12																				

1. Aakifah Yainkain Kamara 200011157
2. Momodou Bah 220032108
3. Alimamy Jarjusey 220032109

 Supervised By
 Prof. Dr. Md. Rezwanul Karim

DEDICATION

This project is in honor of our loved ones back home in Africa.

Their affection, prayers and never-ending help has been our biggest strength in our studies here in Bangladesh.

Their support still reaches us even miles later and encourages us day by day.

It is not we alone who have made the attainment, but they are too.

ACKNOWLEDGEMENT

Firstly, we very much have to thank Almighty Allah (SWT), who is the most merciful and most compassionate, we have the stamina, patience and direction to successfully work on this project.

This work would have been impossible without the guidance, encouragement and helpful suggestions of our supervisor, Prof. Dr. Md. Rezwanul Karim, who helped us and guided us all the time. He offered us a helping hand and understanding which helped us to face numerous difficulties and finish this research. We thank also Mr. Abu Hossain, Senior Foreman Instructor, MPE Department who has helped in design and fabrication part of the study.

All faculty members and friends who helped us and encouraged us in this way are also the people we would like to deeply thank.

Lastly, we owe our parents and families unconditional love, prayers and sacrifices. Without them, we would not have been educated and successful.

ABSTRACT

Access to clean water remains a critical global challenge, particularly in arid and remote regions where conventional desalination systems are costly and energy-intensive. To address this, the present study aims to develop an affordable and sustainable solar desalination unit capable of producing potable water using only solar energy. It is hypothesized that a simple single-slope solar still, optimized through effective thermal insulation, shallow basin design, and proper cover inclination, can significantly improve freshwater yield and overall efficiency. A prototype was designed, fabricated, and experimentally tested at outdoor conditions using a tempered-glass cover, a shallow, black-painted basin, a thermal isolator, a brine drain, and a channel used to collect condensates. The performance was evaluated in terms of temperature distribution, solar energy absorption, and hourly distillate output. The design was to increase thermal retention and evaporation speed based on the literature suggestions regarding the most effective cover angles, shallow water depth, and better insulation. Solar radiation, ambient/basin/glass temperatures, relative humidity, and production of hourly distillate were measured during various test days in August at different levels of irradiance. The daily freshwater yield was found to be at a maximum 1.15 L/day during test days with a maximum thermal efficiency of 39.7% with the highest performance achieved under strong solar irradiance and minimal cloud cover. Incident radiation and operating temperatures were found to have a strong dependence on productivity, and cloud cover and rainfall adversely affected it; the use of an insulation layer and a shallow basin enhanced performance as compared to traditional untreated designs. The modified unit exhibited improved performance with higher efficiency and competitive yield, while preserving a simple design, minimal maintenance, and zero fuel consumption. The findings confirm that a simple, fuel-free, and low-maintenance solar still can effectively provide potable water in resource-limited environments, supporting sustainable development goals related to clean water and renewable energy.

ABBREVIATIONS AND ACRONYMS

Al₂O₃ — Aluminum oxide (nanoparticles/nanofluid)

CFD — Computational Fluid Dynamics

GO — Graphene Oxide

HDH — Humidification–Dehumidification (solar desalination)

MED — Multi-Effect Distillation

MSF — Multi-Stage Flash (distillation)

MSS — Multi-Stage Solar Still

NWRMP — National Water Resources Master Plan

PCM / PCMs — Phase Change Material(s)

PV — Photovoltaic

RO — Reverse Osmosis

SPRO — Solar-Powered Reverse Osmosis

UN — United Nations

TABLE OF CONTENTS

DEDICATION.....	vi
ACKNOWLEDGEMENT	vii
ABSTRACT.....	viii
ABBREVIATIONS AND ACRONYMS	ix
TABLE OF CONTENTS.....	x
LIST OF TABLES.....	xii
LIST OF FIGURES	xiii
Chapter 1 Introduction.....	1
1.1 Background of the Study.....	1
1.2 Importance of Water and Energy in Modern Society	2
1.3 Global Freshwater Scarcity and Environmental Challenges.....	3
1.4 The Role of Desalination Technologies	4
1.5 Overview of Single-Slope Solar Still.....	6
1.5.1 Working Principle:.....	6
1.5.2 Key Components:.....	7
1.5.3 Advantages:.....	7
1.5.4 Disadvantages:.....	7
1.6 Objectives of the study.....	7
Chapter 2 Literature Review.....	9
2.1 Review of Desalination Technologies.....	9
2.2 Solar Desalination Methods	10
2.3 Key Studies on Solar Still Performance	12
2.4 Enhancements to Solar Still Efficiency.....	14
2.5 Applications of Solar Stills in Rural and Disaster-Prone Areas.....	17
Chapter 3 Methodology.....	19
3.1 Solar Still Design Modifications	19

3.2	System Design Description	20
3.3	Description of System Parameters	22
3.4	Mathematical Formulation for Performance Estimation.....	23
3.5	Experimental Setup and Test Procedure	24
3.6	Data Collection.....	28
Chapter 4	Results and Discussions	37
4.1	Performance Evaluation of the Solar Still.....	43
4.2	Heat Transfer Calculations and System Efficiency.....	44
4.3	Comparison with Traditional Solar Stills.....	46
4.4	Potential for Large-Scale Implementation	47
4.5	Challenges in Implementation.....	48
Chapter 5	Conclusion and Recommendations.....	49
5.1	Summary of Findings	49
5.2	Limitations of the Study.....	50
5.3	Future Research Directions	50
5.4	Practical Recommendations for Implementation	50
References	52

LIST OF TABLES

Table 1: Comparison of Solar desalination.....	6
Table 2: Materials selection for fabrication process	28
Table 3: Data collection for day 1.....	30
Table 4 : Data Collection Sheet for Day 2.....	31
Table 5 : Data Collection Sheet for Day 3.....	32
Table 6:Data Collection Sheet for Day 4.....	33
Table 7: Data Collection Sheet for Day 5.....	34
Table 8: Data Collection Sheet for Day 6.....	35
Table 9: Data Collection Sheet for Day 7.....	36
Table 10: Data Analysis Table.....	44
Table 11: Summary of results	46

LIST OF FIGURES

Figure 1: Types of solar desalination (Shah et al)	9
Figure 2: Different desalination method (Shukla & Tiwari, 2018), (Singh et al., 2019).....	10
Figure 3: Schematic diagram of setup	22
Figure 4: Flowchart of solar still operation.....	23
Figure 5: Design of the single slope solar still.....	27
Figure 6: Data collection.....	29
Figure 7: Solar radiation vs time.....	37
Figure 8: Ambient Temperature vs Time.....	38
Figure 9: Basin water temperature vs Time	39
Figure 10: Glass temperature vs Time	40
Figure 11: Distillate collected vs Time	41
Figure 12: Temperature between insulation and Bain water vs time.....	42
Figure 13 : Water Distillation with time	45

Chapter 1 Introduction

1.1 Background of the Study

Water happens to be amongst the most vital components of life on the planet, as it occupies about 80 percent of the surface area on earth. One can hardly imagine that it is possible to survive without it. Simultaneously, energy is the basis of economic growth, and it is a vital component of the functioning of any contemporary economy. The modern world is a very industrialized and technologically advanced society where the presence of sufficient energy can be closely related to development and prosperity. Nonetheless, the explosion of industrialization has not only given rise to the higher demand for fresh water but also to the contamination of the natural water sources. The National Water Resources Master Plan indicates a water demand increase of more than 55 percent by 2025 and this is mainly because of the growth and enhancement of government services. [1] The increasing demand is being spread over to homes, industries, businesses, and municipal infrastructure. To fulfill this increasing demand, it is important to find alternative water resources and implement effective measures, which can facilitate a sustainable and very dependable water supply. The rising environmental pollution and the rising pressure on freshwater have necessitated the implementation of sustainable solutions to ensure that we confront these issues. Solar desalination is one of these solutions, which is a process that turns saline water into fresh and drinkable water using plenty of solar energy. The approach provides a clean and non-pollutant substitute, especially in areas where there is a high level of sun. Desalination technologies can be broadly categorized into two general categories, depending on their way of separating salts and water: thermal separation and membrane separation. These techniques are classified as indirect and direct solar desalination. The latter is concerned with the direct use of sun energy to clean water [2].

The traditional methods of desalination (i.e., indirect solar desalination), despite being effective, are energy intensive and in many cases economically not feasible for vulnerable nations and for arid and coastal areas [2]. Single-slope solar still desalination has in this regard become an alternative that is sustainable. It does not incur fuel expenses, it does not emit any form of energy, and it is eco-friendly. The system can be used to clean the saline or contaminated water by utilizing the natural mechanisms of evaporation and condensation with the help of nothing more than sunlight, without any complicated machines, and not using any sources of power. This comes in handy especially in rural or disaster-prone areas where the

energy infrastructure is scarce or unpredictable. It is also finding more and more application in small-scale domestic use in agricultural environments to give safe drinking water, cooking water, and irrigation water. Its simple design makes it cheap to maintain, and it can be used in water-stressed environments, which are cost-effective and long-term sustainable [3].

1.2 Importance of Water and Energy in Modern Society

The conventional processes of desalination (i.e., indirect solar desalination), even though effective, are energy-consuming and in most instances not economically viable to the vulnerable countries as well as to arid and coastal regions. Solar still desalination of a single slope has in this sense, become a sustainable alternative. It does not consume any fuel, it does not produce any energy, and it is environmentally friendly. Saline or polluted water can be purified with the system by simply applying the natural processes of evaporating and condensing water with the assistance of nothing less than sun rays, no complex machinery, and no power source. This proves useful particularly in rural or disaster-prone regions where power systems are limited or unreliable. It is also increasingly being used in small-scale domestic use in agricultural environments to provide safe drinking water, cooking water, and irrigation water. It is inexpensive to maintain due to its simple design and can be applied in water-stressed environments, which is not only cost-effective but also long-term. Accessibility of clean water in most parts of the world is directly coupled to the use of energy since energy is needed to pump, treat, and relay water over long distances. In the same way, generating energy can often need a lot of water to cool down an even more obvious indication that these two resources are interdependent. The continuing urbanization and industrialization have heightened this interdependence and have complicated water and energy management. As the global populations keep swelling, the water demand is projected to increase by over 55 percent by the year 2025, whereas the energy demand is projected to grow by over 30 percent within the same period [4]. The lack of water along with the unproductive consumption of energy is a major problem for contemporary society. Water scarcity tends to leave countries with increased populations unable to fulfill the demands of their populations, resulting in wars, health complications, and financial turmoil. Equally, the scarcity of fossil fuel as well as the environmental effects of conventional energy production processes also contribute to the problem of energy access and climate change. The need to consider sustainable ways of dealing with water and energy resources has never been of utmost importance. Solar desalination and renewable energy technologies are some of the solutions that can be made to overcome these

challenges by using natural resources that are available in large quantities, such as solar energy, to supply clean water and renewable energy to where it is required the most. It is important to have a balance in the availability of both resources in order to have a secure and prosperous future for the future generations [5].

1.3 Global Freshwater Scarcity and Environmental Challenges

One of the most topical issues of the 21st century can be called global freshwater scarcity. Despite the fact that water comprises approximately 70-percent of the surface of the earth, less than 3 percent of available water is in the form of freshwater, and only a small portion of that is available for human use [6]. The rest of the fresh water is deposited in polar ice caps, glacial formations, and subglacial aquifers and cannot be able to consume or directly use it in industries. This associated scarcity has extended to unprecedented levels on the global water resources, due to the increasing anthropogenic demand, which has added to existing pressures in most regions. In dry and semi-arid regions, the water deficiency is already acute because of already low levels of precipitation regimes and climatic aridity. In this case, the water supply is one of the core geopolitical tensions that lead to competition between states and societies over the limited resource. The United Nations estimates that approximately 2.2 billion people around the world have no access to safely managed drinking-water services, and that over 4 billion of the world population suffer severe water shortages no less than once a month a year [7]. These statistics highlight the severity of the crisis. The increased demand on water has triggered a fast degradation of water quality with the number of pollutants loads taking tally over the natural replacement processes. The global crisis of freshwater shortage is multifactorial, comprising climate change erosion of the reliability of precipitation, occurrence of extreme weather, and accelerated melting of glaciers, resulting in limiting the replenishment of meltwater reservoirs. Population Growth projected headcount of over 9.7 billion people in the world in 2050, increasing water requirements of drinkable, hygienic, agricultural, and industrial systems. Pollution in the form of industrial effluents, urban runoff, and agricultural chemicals on the surface and in the ground. These environmental issues are closely connected with more global aims of sustainable development. The scarcity of water has an effect on the health of the population, agricultural performance, economic stability, and ecological integrity. The field of agriculture that uses about 70 percent of the world freshwater resources is highly susceptible, as it determines food security and socioeconomic balance in many countries. Based on this, in order to curb this alarming problem, there is need to embrace new measures which

can streamline conservation, facilitate optimal utilization and increase other supply routes. One relevant solution is solar desalination which uses lots of solar radiations to produce drinking water at the expense of depleting the available freshwater sources, the technology can become a reliable, ecologically significant fallback option to communities for water-stressed areas but which have limited or polluted fresh water reserves [8].

1.4 The Role of Desalination Technologies

Desalination technologies have become a significant solution to the global water crisis, as they offer a consistent and sustainable source of freshwater out of salty or polluted water. Since freshwater resources face more and more pressure because of population growth, climatic alteration, and pollution, desalination is a promising option to address the increasing demand for drinkable water. Desalination technologies can also sustain communities, industries, and agricultural sectors that are grappling with inaccessibility to clean water through the conversion of seawater or brackish water to consumable water. It is possible to distinguish two major types of desalination which are thermal processes and membrane-based processes, both possessing their benefits and applications based on the needs and resources available in that region. Thermal desalination, also known as distillation, mimics the natural water cycle by evaporating seawater and then condensing the vapor to separate the salt. This method requires significant amounts of heat energy, often supplied by fossil fuels, nuclear power, or renewable energy sources like solar thermal systems. The most common thermal desalination processes include Multi-Stage Flash Distillation (MSF) and Multi-Effect Distillation (MED) [9]. These methods are widely used in regions where access to energy is relatively cheap, and large-scale desalination is necessary to meet the water demands of cities or industrial applications. While thermal desalination is effective, it is energy-intensive and can be costly to operate, especially in regions with high energy costs. Additionally, the brine byproduct generated by the process can pose environmental challenges if not managed properly. Membrane-based desalination technologies, such as Reverse Osmosis (RO), are among the most widely used methods for desalinating seawater. Reverse Osmosis involves pushing seawater through a semi-permeable membrane that allows water molecules to pass while blocking salt and other contaminants. This process is more energy-efficient than thermal methods, making it particularly attractive for areas where energy consumption needs to be minimized. Membrane desalination has become the preferred method for many countries due to its relatively lower energy requirements and ability to produce high-quality potable water. However, the process still requires a significant amount of energy, particularly for large-scale desalination plants. The

disposal of the highly concentrated brine byproduct also remains a challenge, as improper disposal can lead to environmental damage. As global water demand continues to rise, there is increasing interest in developing alternative, more energy-efficient desalination methods. Several innovations are currently being researched to improve the efficiency, environmental sustainability, and cost-effectiveness of desalination technologies. Using solar energy to power desalination processes, solar desalination systems, such as single-slope solar stills, utilize the sun's heat to evaporate water, which is then condensed into fresh water. This method is particularly suitable for small-scale and decentralized applications in regions with high solar potential. Electro dialysis is another type of process that uses electrical fields to drive the movement of ions across a selective membrane, effectively separating salt from water. Electro dialysis is more energy-efficient for brackish water desalination than for seawater, and it is often used in areas where brackish groundwater is the primary water source. Forward Osmosis is relatively new technology that utilizes a natural osmotic gradient to draw water through a semi-permeable membrane [10]. Forward osmosis has the potential to be more energy-efficient than reverse osmosis, though it is still in the experimental phase for large-scale applications. The use of desalination technology involves a set of advantages, mostly to water-scarce regions or those that lack indigenous natural freshwater sources. By offering a consistent water supply within regions that experience drought or seasonal unreliable rainfall that is increasingly frequent with climate change, desalination can help with climate and drought resilience. For the majority of coasts and dry regions, desalination can provide a supplement to natural water resources and help provide drinking water to urban centers, agricultural processes, and industries. Although the process of desalination is not highly energy-efficient, solar and wind technologies that are renewable can be combined with desalination plants to make the process sustainable and decrease the usage of fossil fuels. Economic opportunities exist with decreasing costs of desalination technologies that can avail opportunities to agriculture-based or tourism-based regions that rely on water scarcity. Challenges of Desalination although helpful, desalination technologies experience various setbacks in which particularly reverse osmosis, can be power-hungry, thus being costly in localities with relatively high energy prices. This is why research into lowering the usage of energy and enhancing the effectiveness of desalination procedures has gained much importance. A potential environmental hazard exists with the disposal of concentrated byproducts of associated brine that contain significant concentrations of chemicals and salt. There exists a need to implement innovative technologies of brine management to reduce the effect of associated brine on marine life. Although the expense of desalinated water dropped over the last decades, desalination is typically higher than

abstracting freshwater from natural sources. That can cause desalination to be a less sustainable choice among poor areas aside from regions that have been subsidized or assisted with renewable power [11].

Table 1 compares the single-slope solar still with other types of solar desalination systems based on key factors like efficiency, cost, and scalability.

Table 1: Comparison of Solar desalination

Feature	Single-Slope Solar Still	Double-Slope Solar Still	Reverse Osmosis	Multi-Effect Distillation (MED)
Efficiency	Low	Moderate	High	High
Initial Cost	Low	Moderate	High	High
Energy Source	Solar	Solar	External Power (Electricity)	External Power (Electricity)
Water Production	Low	Moderate	High	High
Suitability for Small-Scale Use	High	Moderate	Low	Low
Environmental Impact	Minimal	Minimal	High (due to energy use)	High (due to energy use)

1.5 Overview of Single-Slope Solar Still

A single-slope solar still is a simple, efficient, and cost-effective device that can be used to convert solar energy to desalination. It works on the basis of evaporation and condensation, making saline or brackish water into fresh drinking water. It is specifically applicable in areas that are marked with limited access to clean water and a high supply of solar irradiance, which makes it applicable in decentralized and small-scale applications.

1.5.1 Working Principle:

Single-slope solar still works through the ability to capture solar radiation to heat saline water, thus triggering the process of evaporation. The consequent water vapor condenses on a chilled surface, and the water is then gathered as fresh water. This is a process that imitates the natural water cycle and is accomplished in the following stages. The sunlight passes through a clear

window (usually that of glass) and supplies heat to the saline water (which is located in the basin under it). The solar heat absorbed by the black-painted basin increases the temperature of the water, leading to evaporation, as a result of which the salts and impurities are deposited. The vapor of the evaporated water rises to the surface, is cooled by the colder surface of the transparent cover, and is condensed into fresh water. The condensed water moves down the inclined face of the cover, and it is pumped into another collecting container, and the brine is pumped out through the outlet [14-16].

1.5.2 Key Components:

This is a glass or plastic cover that allows the sun to come in and the heat to be trapped inside. This is a container that takes in the heat of the sun, thus increasing the temperature of the water in the container. Condensation Surface is the surface of the transparent cover where the vapor condenses to form freshwater. Collection Channel is a sloped plane that directs the condensed water into some collection vessel. Brine Outlet is an outlet to drain off the leftover saline water [14-16].

1.5.3 Advantages:

Single-slope solar stills are cheap to build, and they need low upkeep. It uses renewable solar energy, and it emits no emission. It uses pure sunlight as its power source, therefore making it a long-term solution in areas with scarce energy supplies. Suitable for small-scale or domestic applications in isolated locations [14-16].

1.5.4 Disadvantages:

Low efficiency-generally, solar stills produce a relatively small amount of fresh water. Its functionality is limited to the availability of sunlight, which can hamper performance during cloudy or rainy seasons.

1.6 Objectives of the study

The objectives of this study are twofold. First, to design and fabricate a single-slope solar still using locally available and low-cost materials suitable for practical application in resource-limited areas. Second, to experimentally investigate the performance of the fabricated solar still under various operating and environmental conditions, focusing on parameters such as solar

irradiance, temperature, and water depth to evaluate its efficiency and freshwater production rate. The specific objectives are outlined below:

1. To design and fabricate a single solar still using a low-cost material
2. To study performance of the solar still under various operating conditions

Chapter 2 Literature Review

2.1 Review of Desalination Technologies

Desalination refers to the process of eliminating salts and other impurities from seawater or brackish water to make drinking water. As the intensity and extent of water scarcity increases in the world, especially in arid and semi-arid areas, desalination has become a central technology that supplements the traditional freshwater supplies. Broadly speaking, desalination technologies can be divided into two major groups, namely thermal and membrane-based desalination, both of which have their own advantages, issues, and areas of implementation. Thermal desalination procedures utilize heat to evaporate water, which is then condensed to produce fresh water and leave the salts and other impurities behind. These processes replicate the natural hydrologic cycle in that they use thermal energy to divide freshwater and saline water. In regions that have access to low-cost energy sources or in regions that have salinity in the seawater that is significant, thermal desalination is often utilized. Multi-stage flash distillation (MSF) is a water desalination technology that exploits multiple stages of water separation, allowing desalination of water at varying temperature levels. Multi-stage Flash Distillation (MSF) is a type of water desalination method that utilizes multiple phases of water separation so that water can be desalinated at different temperatures. It is one of the most widely used thermal desalination methods. Figure 1 shows the main types of solar desalination, which are broadly characterized into direct and indirect systems (Shah et al. 2020).

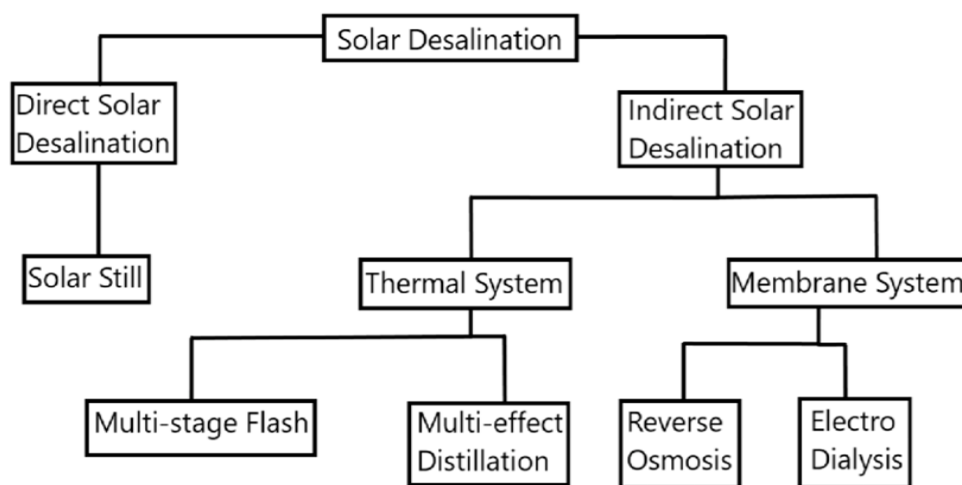

Figure 1: Types of solar desalination (Shah et al)

stages, thus causing rapid vaporization (flashing) at increasingly lower temperatures. Successive stages run at lower pressure than they used to, allowing the water to evaporate at lower temperatures and to obtain an easy production of condensable vapor. The large capacity of production, tested reliability in large-scale processes, and comparatively simple requirements in operations. High energy use, high operational and maintenance costs, and the issue of the environment associated with brine disposal [17].

2.2 Solar Desalination Methods

Solar desalination is a new and sustainable solution to the water crisis facing the world, particularly in areas that have abundant sun rays and limited fresh water supplies. Solar techniques provide a renewable alternative to energy-intensive desalination techniques by using solar energy to power the process of desalination. In most instances, solar desalination systems use solar radiation to evaporate salty water, and the resulting vapor condenses to form fresh, drinkable water. It outlines here the major methods of solar desalination systems, such as solar stills, solar-driven reverse osmosis, solar multi-effect distillation, and solar humidification-dehumidification systems. Both techniques use the solar energy differently to convert saline water into fresh water with different benefits and constraints depending on the particular needs and environmental factors. Solar stills are one of the simplest, though the most commonly used, types of solar desalination. A working solar still is a collection of clear, usually glass or clear plastic, over a black-painted basin to reflect incident sun radiation, thereby warming up the saline water. Evaporation due to the heating effect separates water and dissolved salts. The condensed vapor is gathered as drinkable water on the lower surface of the cover [18]. Figure 2 shows different solar desalination techniques reported in previous studies.

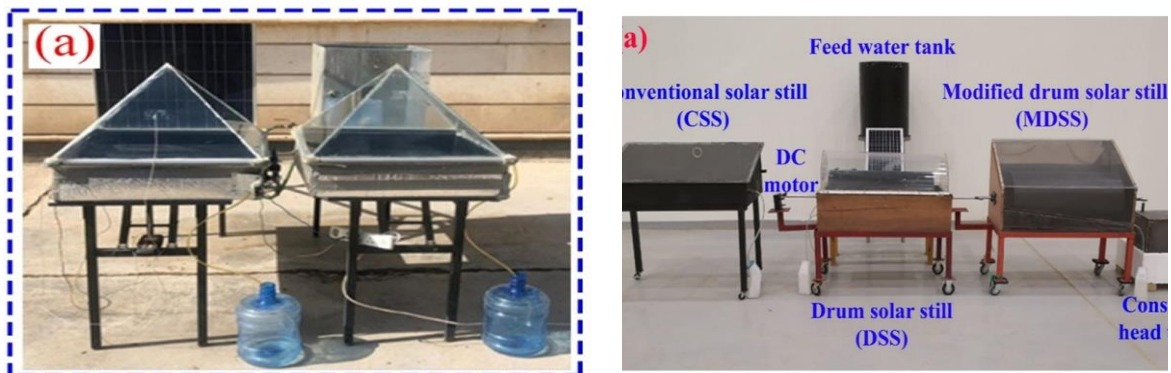

Figure 2: Different desalination method (Shukla & Tiwari, 2018), (Singh et al., 2019)

Single-Slope Solar Stills models have an inclined transparent lid, which directs the condensed water down the slope into a collection tank. It is also naturally simple and costs to design effectively, and therefore, it can be used in small-scale and decentralized applications in rural or remote environments. The stills have two tilted transparent covers that improve the efficiency of the condensation process and thus the freshwater yield. They are normally used in areas where the sun shines at moderate to high levels. In a multi-stage design, a series of solar stills are cascaded, and the stage will further enhance condensation and evaporation. These systems are more efficient in comparison with single- or double-slope systems and allow more water production. Some of the advantages include low cost and simple design, opposite in small-scale use, local materials are easy to maintain and operate. The disadvantages can be low rate of freshwater output, reliance on the supply of sunlight restricts the performance during cloudy weather, takes a lot of land area to use on a large-scale basis. Reverse osmosis (RO) is a commonly used method of desalination where a pressure of water is forced across a semi-permeable membrane that isolates the salts and other harmful substances. The traditional RO systems are based on electrical power, which may be expensive and harmful to the environment in the case of non-renewable sources of electricity. Reverse osmosis systems powered by solar energy (Solar-powered reverse osmosis (SPRO)) systems combine the effectiveness of RO with the usability of solar energy. In SPRO, the electricity required to propel the reverse osmosis process is produced by photovoltaic panels. The solar application reduces the carbon footprint of the system, making it a 17% less harmful environmentally compared alternative to the traditional RO systems that rely on grid electricity or fossil fuels. Some of the advantages are, freshwater production of high efficiency and quality, small- to large-application scalable, green when solar energy is used. Disadvantages can be, massive capital startup on solar panels and RO material, solar power depends on the intensity of the sun, and it requires auxiliary energy storage to operate continuously. Solar multi-effect distillation (MED) is a recent improvement of solar desalination technology that increases the energy efficiency of traditional thermal desalination operations. In MED, a series of stages are used, and several chambers (effects) are used to distill seawater. The water in the first chamber is heated by solar energy, and the vapor produced in turn heats the next chamber and recycles the thermal energy to the benefit of the entire system. The process is especially beneficial in the areas with a high level of solar radiation and is useful in large-scale desalination. MED configurations may be combined with solar collectors (parabolic troughs or solar ponds) and therefore focus solar energy and further increase system efficiency. Advantages can be, more energy efficient than conventional thermal techniques, appropriate in medium- and large-scale

desalination, potential to blend with other renewable sources of energy. Disadvantages are more expensive and complex compared to the less sophisticated solar stills, needs lots of land and infrastructure to operate on a large scale [12]. A more promising solar desalination process is solar humidification-dehumidification (HDH), whereby solar energy is utilized to evaporate water in a source of saline water and then condense the vapor to obtain fresh water. The system usually contains a solar collector that warms up the saline water that is then passed through a humidifier to increase its water content. The resulting humid air is then sent to a dehumidifier, whereby the vapor condenses to fresh water. The method is known to be very simple and with low energy consumption, so it is ideal in areas with low or moderate sunlight and mostly applicable in small- to medium-scale projects. Advantages are, simple and cost-effective, reduced power use, particularly when combined with passive solar systems, compact and suitable for small and medium applications. Disadvantages can be, reduced efficiency and effectiveness compared to other techniques like RO and MED, low capacity of freshwater production, which makes it inappropriate for large-scale desalination. Hybrid solar desalination systems combine different solar desalination methods in order to increase efficiency and fresh water production [16]. An example is that some systems have a combination of solar stills and reverse osmosis, or multi-effect distillation and solar collectors. The aim of such hybrids is to overcome the shortcomings of each of the other approaches, like the low freshwater output of solar stills or the high energy use of RO systems. Advantages can be enhanced effectiveness due to the use of various desalination procedures, design flexibility to customize to different regions and applications, higher scale desalination capacity compared to single solar stills. Disadvantages can be, more complicated and expensive design and implementation, requires a keen incorporation and optimization of different technologies [14].

2.3 Key Studies on Solar Still Performance

The mechanism of solar stills has received a significant amount of academic attention. Scholars have discussed the ways of streamlining the design, increasing efficiency, and discussing the possible solutions to mitigating the problem of water shortage in dry, remote areas. Studies of solar still behavior classically cover a wide range of parameters, such as aqueous production rates, energy efficiency, thermal behavior, design optimization and environmental effects. Here, I give a concise overview of some of the landmark literature on the solar still performance with emphasis on the innovations, challenges, and discoveries that have driven the optimization and realistic implementation of this technology. Single-slope solar stills. Many experimental works on single-sloped systems, which are preferred due to their lean system complexity and

low cost, can offer a good reference point on small-scale desalination solutions. Tiwari et al. (2005) made a comparative evaluation of the thermal efficiency and productivity of the single-slope solar stills in the various environment conditions [19]. The discussion showed that solar irradiance, ambient temperature, and basin water depth have a critical effect on the production rate of single-slope units. Insulation has become an imperative parameter in reducing the amount of heat loss and increasing the effectiveness of the entire system. Key findings were, the power of the solar radiation is proportional to the rate of evaporation, thus, affecting the daily output of distilled-water increased insulation of the basin reduces thermal leakage significantly thus, the increased rate of evaporation in a shallow basin is offset by reduced energy production of a deeper basin in spite of its ability to absorb more heat energy. Impact of design modifications on the performance of solar stills. A number of studies have explored design changes that can be used to augment performance. Velmurugan et al. (2010) compared finned absorbers and sponge liners to enhance the effective evaporative surface area [20]. The experimental findings proved that the use of finned absorbers has an increased effect on heat transfer in water and absorbing substances, thus increasing the yield of water. Sponge liners increase the size of the water -contact area, thereby increasing evaporation. Another experiment by Sajid et al. (2014) discussed the basin material, which is the black-painted surfaces, in the performance of solar still. The two authors concluded that a black basin surface better absorbs heat, increases water temperature, and evaporates faster. The investigation also suggested basin design optimization to increase the production of water. Major discoveries were finned absorbers and sponged liners, swellings are used because they increase the heat transfer area, thus raising the rate of evaporation. A black-painted basin captures more solar energy raising the water temperature, raising its capacity of evaporation; design manipulations like changing the angle of the cover could play a significant role in the performance of solar-still [21]. Summary of the major results were, phase-change materials (PCM) enhance the thermal performance of buildings, in terms of storing heat and releasing heat, which eliminates the need to have direct solar exposure and can maintain an ongoing production process. The joint use of nanofluids and PCMs also enhances heat-transfer efficiency and water yield. The experimental studies of the impact of environmental factors. The environmental conditions such as ambient temperature, humidity, solar irradiance and wind speed have been reported to cause a significant effect on the performance of a solar-still. Nayak et al. (2018) conducted a comparative study of solar stills, putting them in the coastal and inland climates. Their results showed optimal performance with increased solar irradiance and lower ambient temperatures. The coastal locations with high humidity and increased solar exposure tend to perform well.

Key results were, higher rates of solar radiation enhance the rates of evaporation, which in turn increase freshwater availability. Wind speed and humidity do not change the performance, higher humidity inhibits evaporation and lower production, topography, such as being close to a coastline or being elevated, also influences solar-still performance. The solar-still studies of performance, modelling, and simulation. In order to explain the thermal behavior and make optimization of designs easier, a number of researchers have used computational models which simulate the heating and cooling operation [22]. Zarrouk et al. (2013) developed a thermal model of a solar still in an effort to find out relationships that existed between water temperature, heat flux and distillate yield under different conditions. The cross comparison of experiment results made it possible to design optimum parameters of designs of such systems as cover inclination, basin depth, and insulation thickness. At the same time, Garg et al. (2011) applied computational fluid dynamics (CFD) to simulate airflow and heat exchange in solar stills that were designed with different architectural features. The effect of flow distribution and inclination of the covers on the maximization of overall efficiency was pointed out in these studies. In conclusions, computational models define the working principles of heat-transfer and help to optimize the design variables to reach the optimal performance; the results of the simulation prove that alterations in design can significantly increase the performance of solar-still [21].

2.4 Enhancements to Solar Still Efficiency

The productivity of solar stills forms a critical factor of their applicability towards large-scale desalination projects particularly in areas with freshwater deficits. The low water yields of solar stills and their dependence on the solar radiation put significant operational constraints despite their cost-effective and environmental friendliness, despite their relatively low water output. To this end, there has been a lot of research work on how to improve the performance of solar stills in order to boost freshwater production as well as to increase the energy efficiency. This section provides an overview of various approaches and technologies being explored to enhance the efficacy of solar stills and includes design, material and phase change material (PCM) and nanotechnology. One of the main ways through which the efficiency of solar stills can be improved is by refining the basic design of solar stills to enhance heat retention, evaporation rates and condensation. The effect of several design parameters, such as the angle of inclination, depth of water basin, combining solar collectors, and several-stage arrangements have been investigated in multiple studies. The gradient of the solar still cover has a decisive effect on the maximum of collecting condensate. Sajid et al. (2014) reviewed the effect of

inclination angle on a single slope solar still and found that a middle ground of inclination angle (between 20 degrees and 30 degrees) is more conducive to the best condensation rate and the effective distribution of the evaporated water to the collection vessel. The performance of condensation is actually enhanced at steeper angles, but very sharp inclination can lead to water loss and reduced efficiency because of the increased rates of evaporation that cause droplets to fall off prematurely. Similarly, Tiwari et al. (2005) and other researchers that followed them noted that the shallower the basin depths, the faster the evaporation rates, as the thermal mass is reduced hence reducing the time taken to warm the reservoir. Whereas shallow basins increase the rate of heating and boost the total amount of water evaporated per cycle, they also restrict the amount of water that is processed at any given cycle which creates a tradeoff between efficiency and capacity. [20].

Multi-stage solar stills Adding several stages or effects to solar stills can greatly enhance the efficiency of solar stills. Multi stage solar stills (MSS) are a series of stills stacked together, with each stack making the condensation process more efficient with the help of the heat of the previous stage. This cascading design employs the solar energy more effectively which results in more water. Badran et al. (2011) did research on multi-stage solar stills and discovered that the method can also generate water up to 50 per cent more than single-stills. The next step will use lower temperature and uses the remaining heat to evaporate additional water. Also, multi-stage systems can be used to make better use of the space available and are more efficient in regions where the sun is not available all the time. **Application of Phase Change Materials (PCMs)** have turned out to be one of the best methods of enhancing thermal efficiency of solar stills. PCMs are materials that take in or discharge heat when changing state (e.g liquid into solid or solid into liquid). Management PCMs are incorporated in the solar stills to allow storage of extra heat during the day and dissipation during the night, thus allowing the stills to work throughout the days with little sunlight. Ameen et al. (2016) examined the use of paraffin wax PCM in single-slope solar stills and proved that the water yield (1921) increased by 70%. This was credited to the fact that the PCM was able to store thermal energy and then give it up at a constant rate, the result was an evaporation temperature that is constant, and an overall enhancement in the thermal efficiency of the system. On the same note, Elango et al. (2017) investigated the utilization of nano-encapsulated PCMs with aluminum oxide (Al_2O_3) nanofluids, which add to the heat transfer and overall performance. Not only does the use of PCMs increase the operating hours of the solar stills, but it also decreases the reliance of the solar units on the sunlight which enables them to operate during the dark periods especially in

areas where the sun is not constant. Nanotechnology has also introduced new opportunities in order to enhance the performance of solar stills by improving the heat transmission properties of water within the basin. Fluids that contain nanoparticles (e.g., aluminum oxide or copper oxide) are referred to as nanofluids, and have been shown to substantially increase the heat transfer properties of water, resulting in increased evaporation rates. The study by Khulbe et al. (2015) was conducted to determine the application of the Al_2O_3 nanofluids in solar stills and it was established that when nanoparticles are added, the thermal conductivity of the water goes up and evaporation process is enhanced. The research indicated that there was a rise of 25 percent in water production when nanofluids were used as opposed to pure water due to the fact that heat was removed more efficiently at the water interface. Equally, Kaviany (2019) investigated the aspect of incorporation of graphene oxide nano materials in solar stills and discovered that their thermal conductivity was very high to the extent that they consumed less energy which increased efficiency and performance of the solar stills [20]. The addition of nanomaterials helps to enhance the rate at which water absorbs heat, accelerating the evaporation process and increasing freshwater output. Moreover, nanofluids improve energy efficiency by lowering the overall energy consumption per liter of distilled water. This is particularly useful for regions with limited solar energy or when the still works at suboptimal conditions. Solar arrays are glass-enclosed rectangular shapes that absorb solar energy, which is then converted into electricity to power the gadget (Riggs, 2009). Solar arrays are rectangular shapes, which are covered by glass, and then absorb the sun energy, which is then converted into electricity to drive the gadget (Riggs, 2009). The combination of solar collectors in enhancing the thermal performance of solar stills has been a feasible approach in boosting the performance of solar stills in water-heating. Also, commonly in use are flat-plate collectors and parabolic trough collectors which are used to focus the solar energy and then focus it on the still, increasing the total heat input. The solar concentrators direct the sun rays to the basin and more sunlight is used to heat water. Sajid et al. (2013) established that conjoining a flat-plate solar collector and a solar still increased the water output by 50 percent and so conjoining a solar still to a solar collector could save a lot of time, heating water, and thus enhance the total productivity and effectiveness of the system. The environmental issues have led researchers to work not only on the optimization of performance of solar stills, but also on its economic viability and sustainability qualifications. Recent research has been focused on the use of sustainable materials, inexpensive construction methods, and the use of renewable sources of energy, including solar PV panels to operate auxiliary systems. As an example, Singh et al. (2020) designed a low-cost solar still that deployed recycled materials and found that the

reengineered version worked well in the conditions similar to the traditional systems and could be economically viable when deployed to rural and off-grid areas. The paper has also emphasized that the cost of initial investment can be minimized, which can lead to the widespread implementation of solar desalination technology in underdeveloped areas [18-22].

2.5 Applications of Solar Stills in Rural and Disaster-Prone Areas

Solar stills are easy to install, cheap, and use renewable energy, thus attracting more and more attention as a way of fresh water supply in the rural and disaster-prone regions. Most of these areas have poor access to clean water, ineffective infrastructure, and they have a poor energy supply. Solar stills are the best alternative since they utilize the large solar radiations to clean water without the use of sophisticated equipment and electricity. They come in particularly handy where there is no means of traditional water treatment and electricity, or it is not feasible. Solar stills will be suitable in remote and rural areas with limited or contaminated freshwater in the vicinity. Off-grid communities can use them as a source of energy because their low start-up and maintenance costs make them viable sources of energy. Investigations by Tiwari et al. (2005) and Sajid et al. (2014) indicate that single and multi-slope stills are capable of satisfying the domestic demand of small-scale facilities, which provide clean water to drink, cook, and irrigate plants [18].

They are scalable to serve entire communities and thus can be used in bigger projects like irrigation in agriculture or in small industries. The major advantage is that solar stills do not require any external power they do not need any electricity and fossil fuel, so they are necessary in the regions where there is scanty energy infrastructure or flak in the electricity supply. Solar stills are self-sufficient, totally solar-powered and capable of supplying intermittent fresh water when the sun is out. They can fit into the diverse socio-economic settings due to their simplicity and their ability to be adjusted to the local conditions of materials. Solar stills will be essential in disaster-prone areas like earth quakes, flooding, hurricanes among others where raw water poses a threat to emergency supply. Clean water is very difficult to access after a disaster because the local ones are usually contaminated. Solar stills are easy to transport and capable of supplying emergency drinking water purification, which is a sure source as soon as an occurrence. They are highly useful in humanitarian relief effort due to their portability and easy deployment. The study of Ameen et al. (2016) affirms that solar stills are essential in disaster response efforts since the appliances are portable and can be used easily to provide the populations in need with safe drinking water [21].

Solar stills can also be used to support small-scale farming in the rural areas to provide safe drinking water. In such regions, water scarcity is the greatest leading to low agricultural production and threatening food security. Solar stills have the potential of improving agricultural output and improving the livelihoods of farmers by providing a steady supply of freshwater to irrigate crops. As evidenced by Velmurugan et al. (2010) and Sajid et al. (2013), solar stills can be used to enhance agricultural sustainability in arid and semi-arid areas, and it provides an inexpensive and environmentally-friendly system to purify water and use it in irrigation [23].

Although solar stills have many advantages in rural and disaster-prone regions, low rates of freshwater production, reliance on the availability of sunlight, and a low scaling factor remain. Nevertheless, current development in the solar still design, including the incorporation of phase change materials (PCMs) and nanofluids, is geared towards enhancing efficiency and enabling solar stills to be more flexible for a broader scale application. With the ever-evolving nature of these technologies, solar stills have the potential to transform water shortage scenarios in isolated and flood-prone areas even further in the context of developing sustainable water management solutions in the areas where traditional desalination processes cannot be implemented [24].

To sum it up, solar stills are a future-perspective and viable remedy to supplying clean drinking water in the rural and disaster-affected regions. They are easy to use, expensive, and use renewable energy, making them suitable to use in off-grid and decentralized applications. With the ongoing development of solar desalination technologies, solar stills will have a major role in reducing the effects of water scarcity as well as providing safe drinking water in areas that are threatened by water scarcity across the globe.

Chapter 3 Methodology

This chapter outlines the methodology used in the design, fabrication, and performance evaluation of the solar still system. The primary focus of the study is to design and construct a single-slope solar still for desalinating saline or brackish water using solar energy. The methodology includes the design modifications, system setup, experimental procedure, and performance estimation techniques used to assess the efficiency of the system.

3.1 Solar Still Design Modifications

This chapter systematically outline the methodological framework used in designing, manufacturing, and evaluating the solar still system that is proposed in this chapter. The key objective of the project is to design and build a single-sloping solar still that will be able to salinate saline or brackish water by means of sunlight radiations. The methodology involves design optimization, system assembly, experimental testing and performance evaluation to test the efficiency of the apparatus. The design of a solar still has a decisive effect on the thermodynamic efficiency and the overall performance of the solar still. Traditional (single)-sloped solar stills include a tank of saline or brackish water, a transparent cover to enclose the sun rays, and a sloping surface to make the condensed condensate flow into a pool. In order to improve the system performance, various design modifications have been explored with the particular aim of maximizing heat retention, increasing evaporation rates, and increasing water throughput. The condensation kinetics are highly controlled by the inclination of the transparent cover. The angle of the cover has a direct effect on the collection efficiency by controlling the area of the surface to be covered to store condensate. Empirical literature like that by Tiwari et al. (2005) has shown that a slanted cover of modest slope (usually between 20 and 30 degrees) enhances condensation but reduces excessive evaporation and so ensures that the water is in contact with the condensate surface long enough to recover a significant amount of freshwater [23-24]. Solar heat uptake requires the use of an optimized basin geometry. Absorptivity can be increased by painting the basin black, with darker colorants as compared to lighter ones absorbing more solar energy. Moreover, the use of a shallow basin depth helps to reduce thermal inertia and stimulate the quick heating of water and speed up evaporation. The low basin depth may allow the rate of evaporation to be higher at a certain time, but it also limits the quantity of water that can be treated in a cycle. The base of the still and the side walls were later thermally insulated to limit the conductive and convective losses of heat to the surrounding environment. Proper insulation maintains high temperatures in the

basin and thus maintains a high rate of evaporation. It is a quality that is especially noticeable at nighttime or on rainy days when the sun cannot be seen clearly, as it enables the still to work with long durations. The product includes an inbuilt solar collector as well as a battery that is both larger and more durable than that of the Tropism home solar collector. An additional solar collector can be added to preheat the saline inlet water before entering the still to further enhance thermal efficiency. This preheating stage increases the temperature of the input, thereby shortening the time for water to reach the boiling point and ultimately increasing the total water yield [22].

3.2 System Design Description

The concept of the solar still system is developed as a small and low-cost desalination device that uses solar energy to purify water as seen from Figure 3. It consists of a number of discrete elements that are placed in strategic positions to complement the overall output and effectiveness of the assembly. The main components and their functions include the following:

Transparent Glass Cover

The casing is made of tempered glass, with dimensions of 99.89 cm x 47.5 cm (average 40 in by 19 in) with a thickness of 0.5cm. Its main role is to block the solar radiation and decrease the thermal dissipation of the system. The translucency of the cover permits photons of the sun to enter and hence warm the water in the basin. In addition, the angular cover orientation provides the directed flow of the condensed water to the collection conduits, thereby providing efficiency in the condensation and retrieval of the condensates.

Galvanized iron Basin

Its basin containing the saline feed is made black to maximize the solar absorption. Its size is 91cm in length, 41cm in width, and 5 cm in depth. The low depth enhances quick loading of thermal energy, and this increases the rate of evaporation.

Brine Drain Pipe

The concentrated saline effluent left after the evaporation process is removed by the use of the brine drain pipe. It pushes salt and other impurities out of the basin, avoiding their accumulation

to slow the process of further evaporation. It also allows storing of the concentrated fresh water separately.

Freshwater Collection Pipe

The collection pipe of the fresh water is underneath the sloping glass cover and the condensed water moves to a special reservoir. Its design gives the water a smooth flow and eliminates stagnant areas hence easy to collect and store. The system will be aimed at maximizing production and reducing wastage of distilled water.

Support Structure

The entire assembly will be attached to a fixed rigid support structure consisting of mild steel angles. The skeleton provides the required mechanical stability and provides easy adjustments of the position of the still to best utilize the sun throughout the day. The support is also designed to perform in different climatic conditions hence the solar still will be in use despite the environmental variables changing

Water Storage Containers

The system keeps the saline feed, brine and distilled water in plastic or stainless-steel containers that are food grade. These are easy to access and monitor containers in which users can monitor the fluid levels easily. They are huge in size to contain enough water in such a way that the distillation process may be smooth without any hitch.

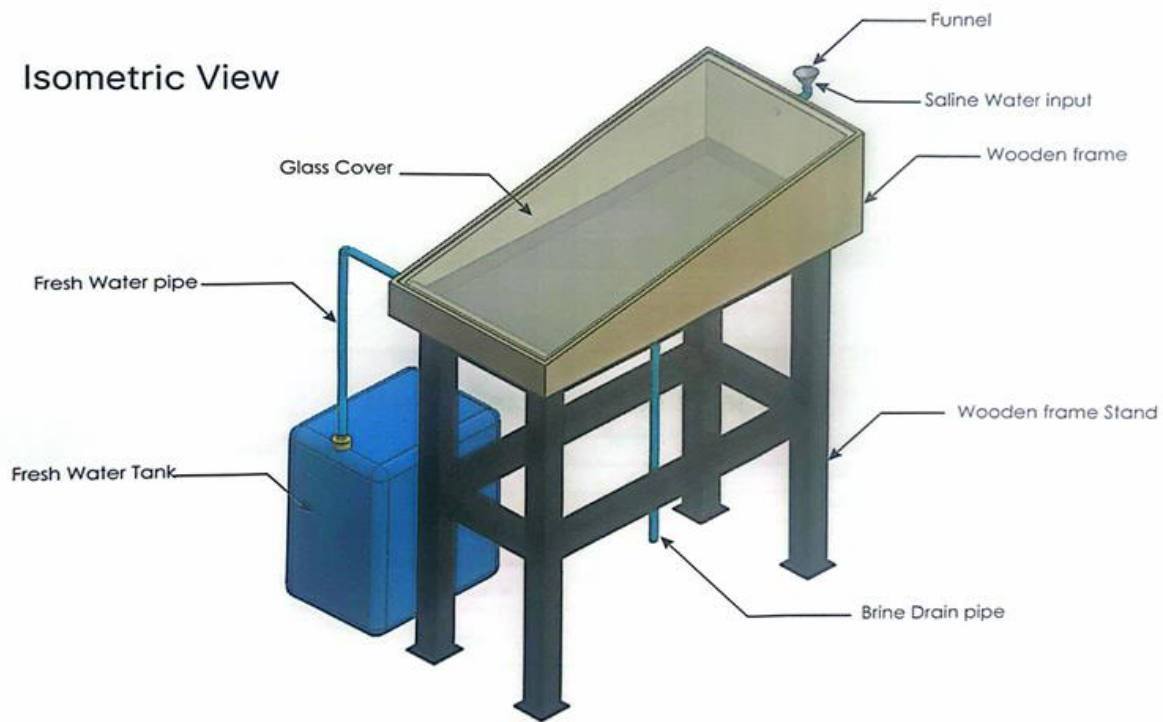

Figure 3: Schematic diagram of setup

To precisely measure the performance of the solar still, there is a need for systematic measurements of important parameters during the experimental regime. Such measurements cannot be ignored in the process of assessing the effectiveness of changing saline feedwater into potable product. The basic energy source to the still is the solar irradiance. Its strength varies due to geographical latitude, solar height, and the clearness of the atmosphere. An in-situ irradiance was measured using a calibrated photometer to give important data to correlate the input energy to freshwater generation. The rate of evaporation is decisively impacted by the temperature of the saline bath. Temporal variations in temperature within the basin are recorded using thermometric values taken at specific locations at which the experiment takes place and thus can be used to determine thermal responsiveness and evaluate how design changes affect heat transfer. The distilled water rate, which is the rate of the generation of distilled water, is directly proportional to the efficiency of the system. Empirical data on the performance of the freshwater reservoir production is provided by the periodic volumetric measurements thus, it is used to inform the optimization strategies. Humidity and Temperature of the surroundings. The surrounding temperature and the humidity level have an immense effect on solar still performance. High temperature and low humidity tend to promote the accelerated rates of evaporation. The measurement of these environmental parameters is done by means of the use of weather stations that are situated closely to the solar still. Solar still energy efficiency is measured by comparing the energy input, mostly solar radiation and energy

output, freshwater production. This measurement provides the foundation for evaluating the performance of the system and defining the potential line of improvement in it. Figure 4 illustrates the flowchart of a solar still.

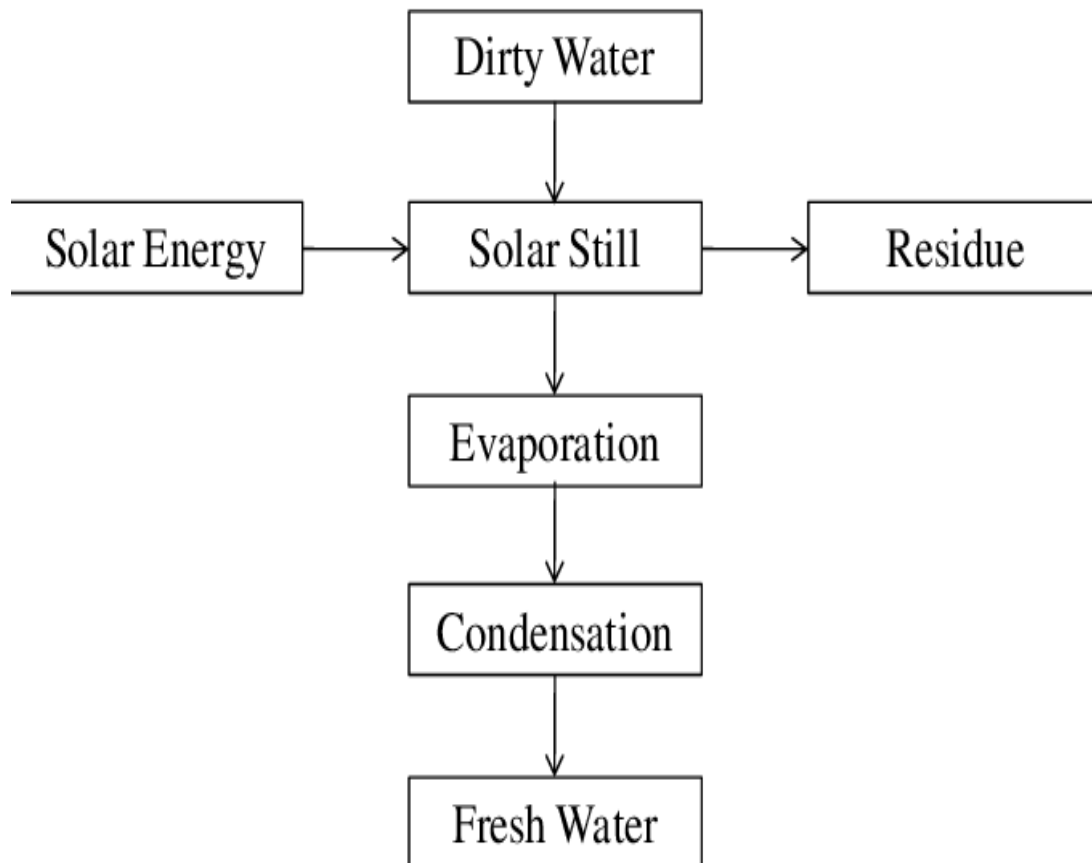

Figure 4: Flowchart of solar still operation

3.4 Mathematical Formulation for Performance Estimation

Solar still performance is extrapolated based on mathematical models based on combining the processes of heat transfer, evaporation, and condensation efficiency. The main goal is to determine the energy efficiency and rate of water production in relation to the input parameters that include solar radiation, water temperature and basin area.

Heat Transfer Coefficients:

The heat transfer coefficient of evaporation (h_{wg}) and convection heat transfer coefficient ($h_{c,wg}$) are calculated based on the conventional equations that are outlined by Zarrouk et al. (2013) and other researchers in the field. These coefficients assist in estimating the amount of heat taken in the water and heat transfer efficiency.

Energy Balance Equation:

The equation of energy balance is used to calculate the energy input and output of the system. It takes into account both the heat that the saline water absorbs, the heat that is given out to the environment and the amount of heat given to the evaporation. Generalized form of the energy balance equation is:

$$Q_{in} = Q_{evap} + Q_{loss} \quad (1)$$

where

Q_{in} is the total energy absorbed from solar radiation,

Q_{evap} is the energy used for evaporation, and

Q_{loss} is the energy lost to the environment.

Water Production Estimation:

The rate at which freshwater is produced is calculated by monitoring the amount of freshwater that is collected within a given period of time, and then divided by the time that the experiment takes. The rate of production may be written as:

$$V \cdot fresh = \frac{\Delta V_{fresh}}{\Delta t} \quad (2)$$

where *V fresh* is the freshwater production rate,

ΔV_{fresh} is the change in freshwater volume, and

Δt is the time interval.

3.5 Experimental Setup and Test Procedure

The experiment was conducted at the Islamic University of Technology (IUT), Dhaka, Bangladesh, under natural climatic conditions to study the performance of the single-slope solar still. To start with, a prototype model was first designed to verify the working concept. Afterward material research was conducted where local, durable, and cost-effective parts were purchased to build. The angle frame made of mild steel (MS), galvanized iron basin, glass cover, UPVC board, water storage tank and some miscellaneous items were purchased. Fabrication was made on the components and fitted them in the workshop. First trial test was conducted to ensure that there were no leakages and the system was sealed and firmly balanced. Before each experiment, four liters of saline water were added into the basin. To be able to

measure the changes in temperature throughout the day, we installed a set of thermocouples at different locations to the basin water, the inner glass surface, the vapor zone, and even to the air surrounding the whole basement. Solar irradiance was measured with a solar power meter. The solar still was operated daily under ambient weather conditions, typically from 8:00 AM to 5:00 PM. However, the performance varied depending on solar intensity that is on days with low sunlight, the distillate output decreased significantly. On days with high sunlight, the distillate output increases. The peak operational period was generally observed between 12:00 PM and 2:00 PM, when the solar radiation was highest. A water channel trough was used to collect distillate production every hour. A graduated measuring cylinder was used to measure the amount of distillate water that was collected every hour per milliliters. It was an excellent method of ensuring that the performance of the system over time was observed.

Figure 5 illustrates the dimensions and geometric configuration of the prototype used for the experiments which provide detailed measurements necessary for fabrication and performance evaluation. These dimensions were maintained consistently across all tests to ensure comparability and accuracy of results.

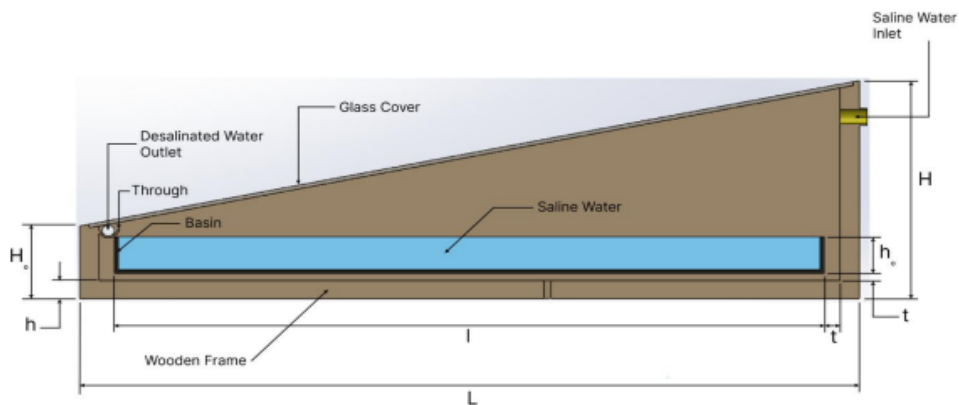

Symbol	Definition	Measurement
H_0	Front wall high	10 cm
H	Back wall high	30 cm
h_0	High of the basin	5 cm
h	Thickness of the wooden frame	2.5 cm
L	Length of the wooden frame	100 cm
l	Length of the basin	91 cm
t	Gap between the wooden frame for the insulation	1 ~ 2 cm

(a)

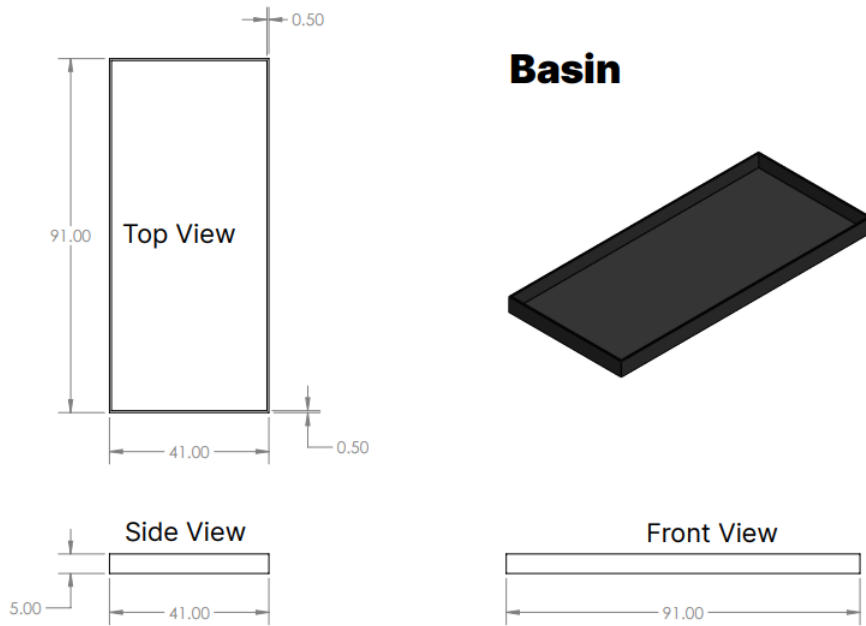

All dimensions are in cm

(b)

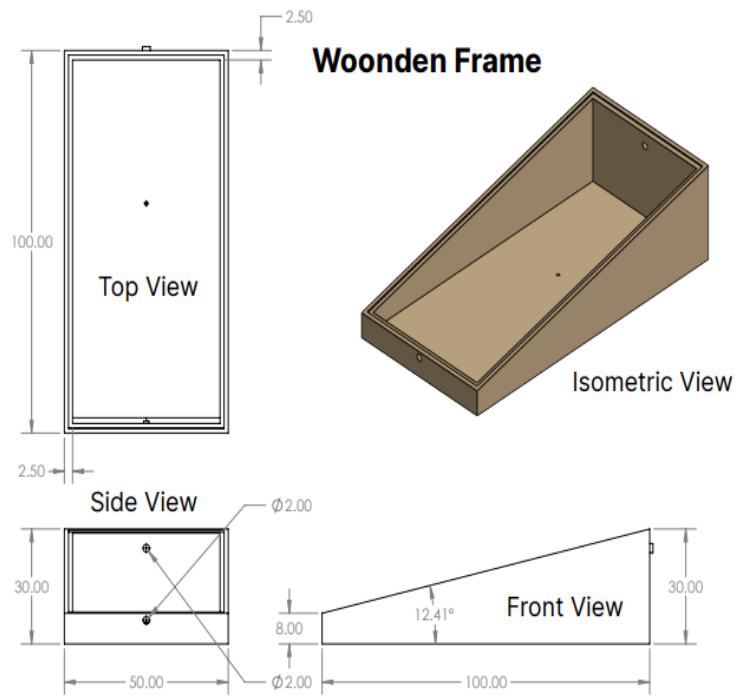

All dimensions are in cm

(c)

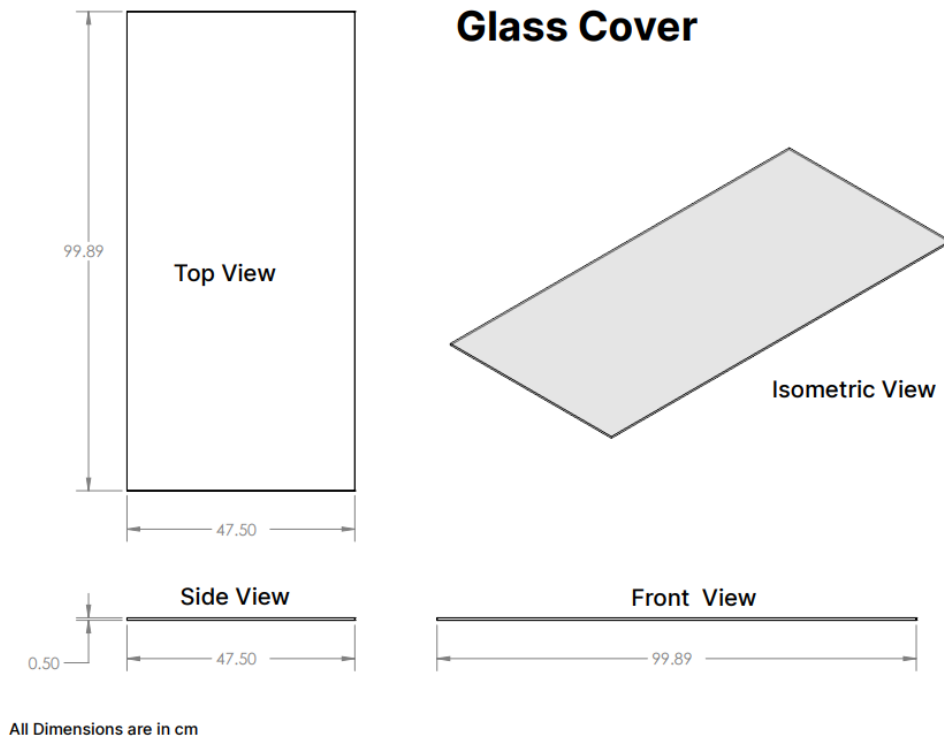

(d)

Figure 5: Design of the single slope solar still

Table 2 summarizes the materials selected for the fabrication process. Each material was chosen based on its mechanical properties, availability, and suitability for the prototype's functional requirements ensuring that the design meets both structural and operational criteria.

Table 2: Materials selection for fabrication process

Item no.	Material/Equipment	Description
1	Transparent Glass Cover	Tempered glass cover (1 m x 0.5 m) (3.28 ft x 1.64 ft), 4-6 mm thick, for the desalination unit to allow sunlight penetration and prevent contamination.
2	Basin	Length: 91 cm, Weight: 41 cm and Hight: 5 cm Capacity: 16 L of saline water.
3	Water storage containers/Tank	Food-grade plastic or stainless-steel tanks for storing feed water, brine water and distilled water. Capacity: 5 L Water
4	Silicon Glue	For sealing the joints pipes and fitting system
5	Insulation Material	This is to prevent heat loss
6	Support structure	MS Angle (1.5'' x 1.5'') 4 stand member x 1m (3.28 ft) 4 big cross member x 1m (3.28 ft) 2 small cross member x 1m (3.28 ft) Total: 12m (48 ft)
7	Wooden Frame	For the desalination unit
8	Miscellaneous	Significant for any additional material left out

3.6 Data Collection

The following are observed in the course of the experiment: solar radiation (through the use of solar meters) as well as the temperature of the water (through thermometers), temperature and humidity of the atmosphere (weather stations), and freshwater volume (measuring cylinders). The experiment normally takes the course of 4-6 hours depending on the amount of solar energy available. The effectiveness of the solar still is determined by how much fresh water it can yield, the energy efficiency, and the ability to perform consistently under different conditions of the environment. Experimental data analysis is done to establish correlations between solar radiation, temperature, and the freshwater yield. Figure 6 presents the overall

experimental procedures used to perform the tests. The setup consists of a test frame equipped with the necessary apparatus, thermocouple sensors, and measuring cylinder.



Figure 6: Data collection

Table 3 to 9 presents the data collected for various day during the performance study.

Data Collection Sheet

Date: 31-08-2025

Table 3: Data collection for day 1

Time	Solar Radiation (W/m ²)	Ambient Temperature (°C)	Basin Temperature (°C)	Glass Temperature (°C)	Distillate Collected (ml)	Temperature between Insulation & Basin Water (°C)
08:00 AM	157	28.7	33.4	30.1	14	31.0
09:00 AM	200	28.5	33.7	30.2	15	31.1
10:00 AM	850	21.8	34.9	32.0	21	33.0
11:00 AM	950	30.5	35.6	35.6	27	35.4
12:00 PM	207	32.5	56.5	39.5	27.5	38.6
01:00 PM	180	29.3	43.1	37.8	49.5	36.0
02:00 PM	172	30.8	66.0	40.4	15	37.1
03:00 PM	240	33.4	65.8	39.0	35	38.2
04:00 PM	158	34.0	62.5	37.5	28	36.0
05:00 PM	95	32.0	59.0	35.0	22	34.5
06:00 PM	83	31.5	56.0	33.0	27	32.0

Remark:

After 2 PM it was cloudy, there was no drop of water coming.

Data Collection Sheet

Date: 01-09-2025

Table 4: Data Collection Sheet for Day 2

Time	Solar Radiation (W/m ²)	Ambient Temperature (°C)	Basin Temperature (°C)	Glass Temperature (°C)	Distillate Collected (ml)	Temperature between Insulation & Basin Water (°C)
08:00 AM	200	30.5	34.0	32.0	10	30.5
09:00 AM	550	32.0	55.0	38.0	45	35.5
10:00 AM	800	34.0	70.0	40.5	85	38.0
11:00 AM	978	36.3	88.8	41.0	100	42.5
12:00 PM	986	37.9	88.9	42.5	140	44.6
01:00 PM	891	37.3	88.9	44.1	190	45.3
02:00 PM	810	45.1	86.2	46.5	180	47.2
03:00 PM	540	41.5	82.4	43.1	140	40.1
04:00 PM	255	37.2	68.0	38.5	62	34.0
05:00 PM	130	35.5	61.0	36.0	45	33.0
06:00 PM	100	34.0	58.0	34.5	40	31.5

Remark:

- After 2 PM it was cloudy, there was no drop of water coming.

Data Collection Sheet

Date: 02-09-2025

Table 5: Data Collection Sheet for Day 3

Time	Solar Radiation (W/m ²)	Ambient Temperature (°C)	Basin Temperature (°C)	Glass Temperature (°C)	Distillate Collected (ml)	Temperature between Insulation & Basin Water (°C)
08:00 AM	150	29.0	35.0	28.0	50	30.0
09:00 AM	300	30.0	40.0	29.0	70	33.0
10:00 AM	600	31.0	45.0	30.0	90	35.0
11:00 AM	911	31.5	48.2	30.0	140	38.0
12:00 PM	938	34.4	58.3	31.1	140	40.3
01:00 PM	1073	36.6	66.5	35.9	140	44.7
02:00 PM	583	37.8	62.0	35.3	325	45.6
03:00 PM	213	38.3	56.8	35.1	325	36.7
04:00 PM	113	33.1	41.5	34.1	80	31.1
05:00 PM	80	32.5	39.0	33.0	60	30.0
06:00 PM	40	31.0	36.5	31.5	50	28.5

Remark:

- From 08:00 to 11:00 AM, it was partially cloudy. From 05:00 PM inward, it was raining.

Data Collection Sheet

Date: 03-09-2025

Table 6: Data Collection Sheet for Day 4

Time	Solar Radiation (W/m ²)	Ambient Temperature (°C)	Basin Temperature (°C)	Glass Temperature (°C)	Distillate Collected (ml)	Temperature between Insulation & Basin Water (°C)
08:00 AM	150	28.5	33.5	30.0	20	29.5
09:00 AM	650	37.9	88.8	38.7	37	36.2
10:00 AM	682	40.3	88.8	41.1	62	38.7
11:00 AM	263	37.0	51.1	37.2	191	46.3
12:00 PM	938	35.1	59.2	36.8	98	42.2
01:00 PM	968	37.0	55.2	37.2	52	41.2
02:00 PM	235	35.0	50.9	34.9	40	35.5
03:00 PM	698	30.1	35.2	33.1	30	33.8
04:00 PM	120	28.5	32.0	31.5	15	30.5
05:00 PM	50	27.5	30.0	29.0	10	29.0
06:00 PM	30	26.5	28.0	27.0		

Remark:

- After 3 PM it was cloudy, there was less water yield.

Data Collection Sheet

Date: 04-09-2025

Table 7: Data Collection Sheet for Day 5

Time	Solar Radiation (W/m ²)	Ambient Temperature (°C)	Basin Temperature (°C)	Glass Temperature (°C)	Distillate Collected (ml)	Temperature between Insulation & Basin Water (°C)
08:00 AM	150	28.5	35.0	31.5	20	30.0
09:00 AM	400	30.0	42.0	33.0	35	32.0
10:00 AM	650	32.5	46.0	34.5	40	35.0
11:00 AM	992	36.5	48.5	35.4	48	40.1
12:00 PM	1061	34.7	54.3	38.9	40	47.0
01:00 PM	982	35.1	58.3	37.0	82	49.6
02:00 PM	150	37.0	57.0	41.6	70	39.6
03:00 PM	100	38.0	57.9	42.2	91	39.3
04:00 PM	60	37.5	55.0	40.0	60	38.0
05:00 PM	30	36.0	52.0	38.0	50	36.0
06:00 PM	20	35.0	49.0	36.0	40	34.0

Remark:

- Partial cloud in the morning. We start taking reading at 10:00 PM; After 02:30 Pm it was cloudy we couldn't take reading anymore.

Data Collection Sheet

Date: 06-09-2025

Table 8: Data Collection Sheet for Day 6

Time	Solar Radiation (W/m ²)	Ambient Temperature (°C)	Basin Temperature (°C)	Glass Temperature (°C)	Distillate Collected (ml)	Temperature between Insulation & Basin Water (°C)
08:00 AM	120	32.0	45.0	35.0	15	33.5
09:00 AM	229	41.5	53.2	40.8	20	49.3
10:00 AM	360	36.0	56.0	44.0	40	46.1
11:00 AM	301	38.9	53.2	39.7	65	48.3
12:00 PM	787	41.2	56.3	40.7	75	51.5
01:00 PM	375	37.9	53.6	39.1	65	48.6
02:00 PM	300	37.2	53.0	39.0	50	42.3
03:00 PM	158	35.9	47.3	37.4	30	37.8
04:00 PM	95	34.7	41.7	30.5	10	38.1
05:00 PM	70	34.0	40.0	29.0	8	35.5
06:00 PM	40	32.5	38.0	27.0	5	33.0

Remark:

- After 2 PM it was cloudy, there was less water yield.

Data Collection Sheet

Date: 07-09-2025

Table 9: Data Collection Sheet for Day 7

Time	Solar Radiation (W/m ²)	Ambient Temperature (°C)	Basin Temperature (°C)	Glass Temperature (°C)	Distillate Collected (ml)	Temperature between Insulation & Basin Water (°C)
08:00 AM	150	30.5	40.0	31.5	15	31.0
09:00 AM	300	32.0	42.5	32.0	25	34.0
10:00 AM	400	32.5	44.0	32.5	28	36.0
11:00 AM	500	33.0	44.5	33.0	30	37.0
12:00 PM	448	33.5	45.3	32.9	30	39.7
01:00 PM	349	34.1	46.1	34.8	40	41.8
02:00 PM	556	33.8	45.5	34.1	35	41.9
03:00 PM	250	32.4	45.3	32.3	25	32.3
04:00 PM	150	31.8	43.0	31.5	20	30.5
05:00 PM	90	31.2	41.5	30.0	15	29.0
06:00 PM	50	30.0	39.0	28.0	10	27.0

Remark:

9:00 and 10:00 AM was over cast cloud (fully covered). 11:00 AM, Cloud cover and precipitation. Reading Stops at 03:00 PM due to Cloudy, and small raining.

Chapter 4 Results and Discussions

This part reports and discusses the experimental results of the single-slope solar still system. Measurement of performance is based on parameters like rate of water production, efficiency and calculation of heat transfer. Contrasts of results with those of conventional solar stills are provided and the potential of mass introduction is evaluated. The issues related to the practical implementation are also discussed to update the future research and enhancements.

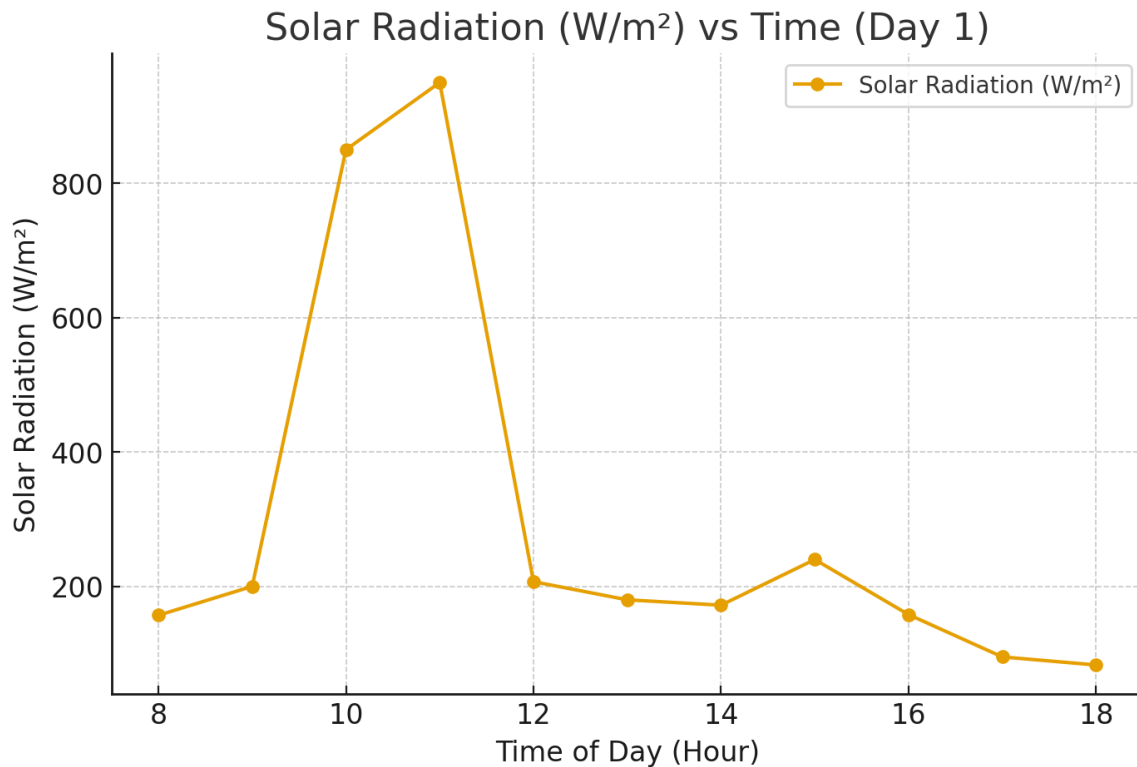

Figure 7: Solar radiation vs time

Figure 9 shows the solar radiation with time for Day 1. The solar radiation begins relatively low in the morning (157 W/m² at 08:00 AM), reaches its maximum at 11:00 AM (950 W/m²) and decreases in the afternoon, reaching 83 W/m² only at 06:00 PM.

This has a diurnal trend of solar radiation with a peak of 2pm but it is interesting to notice that at 12pm the radiation decreases to 207 W/m² maybe there is cloud cover, shadow, or some turbulence in the atmosphere.

The figures show that the intensity of the sun was highest prior to noon and not at noon.

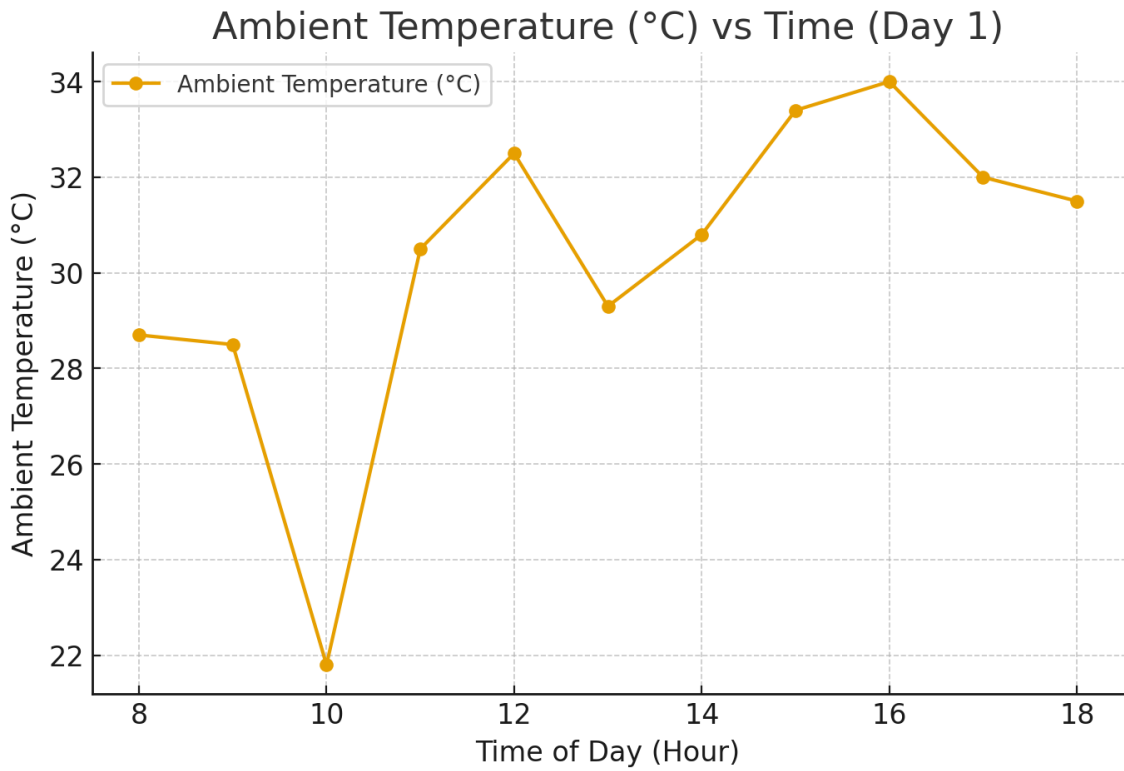

Figure 8: Ambient Temperature vs Time

The ambient temperature slowly turns up between 21.8 °C at 10:00 AM and approximately 34.0 °C at around 04:00 PM and then slightly dips down towards the evening as seen from Figure 10.

The daily trend shows natural heating of the environment with solar radiation increasing and the peak ambient temperature matches with the afternoon hours from 3-4 PM.

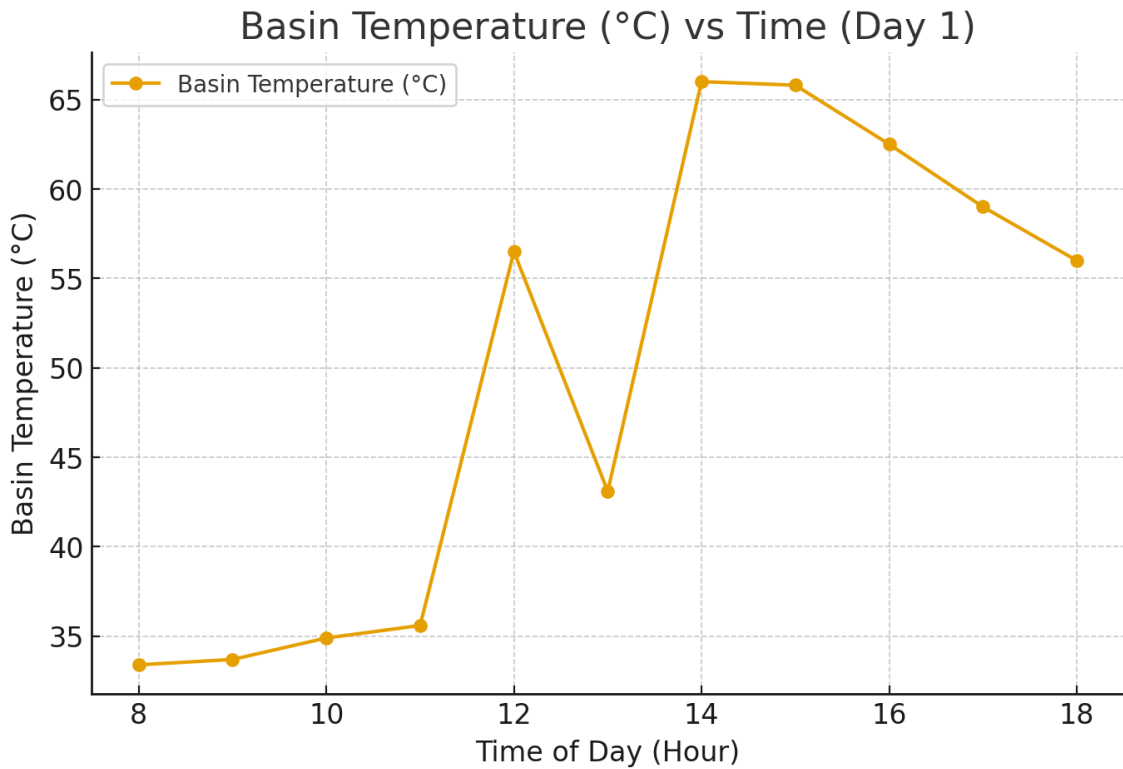

Figure 9: Basin water temperature vs Time

Figure 11 shows the basin temperature rise with time. The temperature in the basin increases during the day with 33.4 °C at 08:00 AM and 66 °C at 02:00 PM.

The trend shows a high heat absorption capacity of the basin, but some lag is present relative to solar radiation on account of thermal storage.

Although the incident of solar radiation declined after noon, the basin temperature was relatively high because of the retained heat.

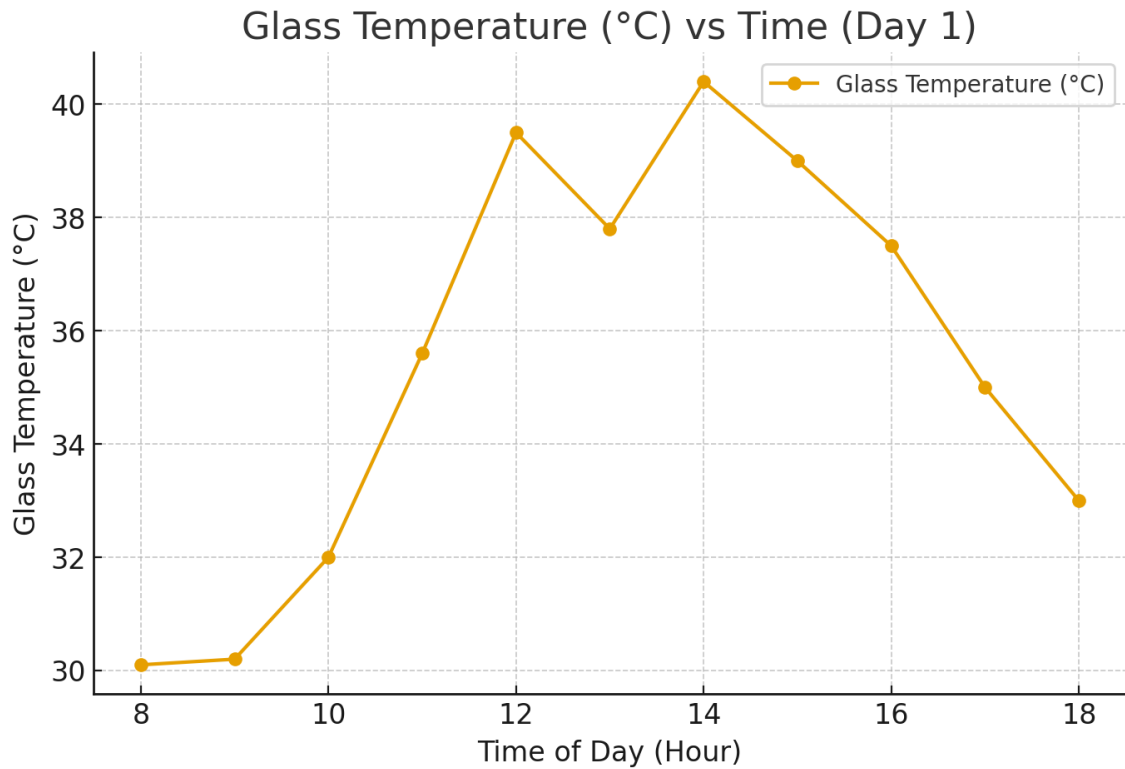

Figure 10: Glass temperature vs Time

The temperature of the glass (Figure 12) is directly dependent on the temperature of the basin yet is always lower in the morning and afternoon (30-40 °C).

The highest temperature of 40.4 °C at 2:00 PM corresponds with the highest basin water temperature.

As the glass is open to the air, it also heats fast once peak hours are reached, providing a less extreme upswing and downswing than basin water.

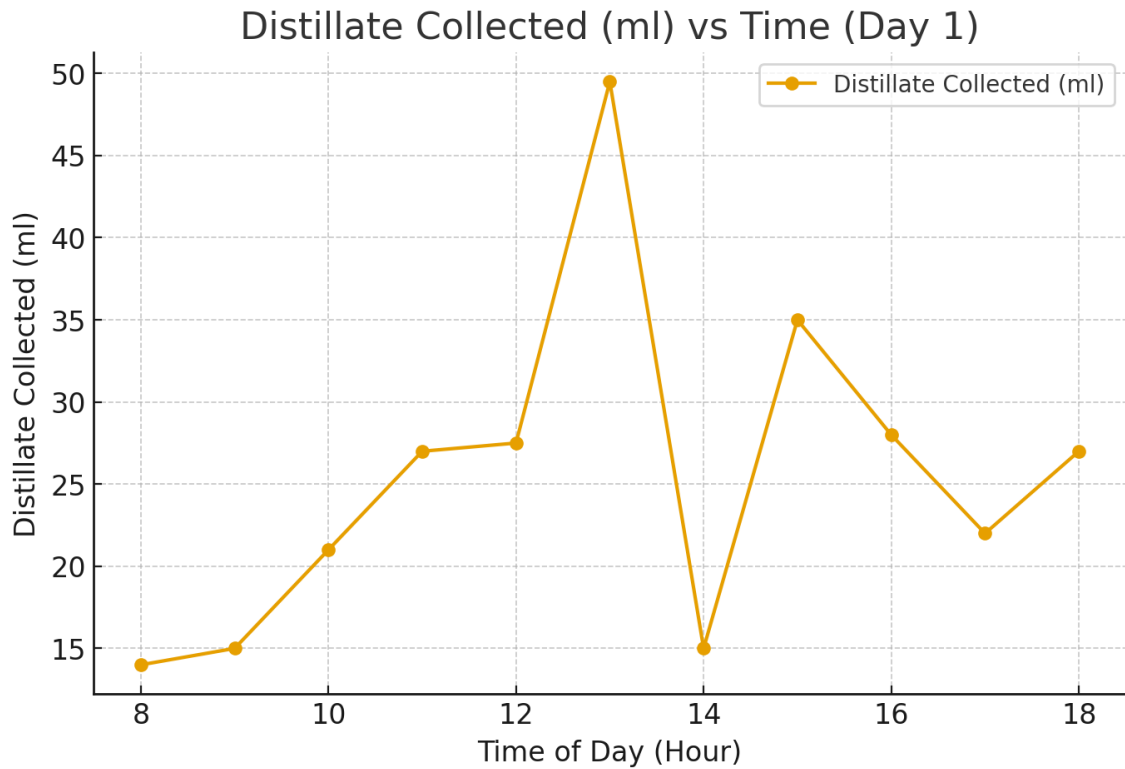

Figure 11: Distillate collected vs Time

Figure 13 plots the hourly distillate collection. The output of the distillate is gradually increasing with time to a maximum at 01:00 PM measuring 49.5 ml.

The trend of production is not only a matter of solar radiation; rather, it is related more to the sum of the differences in the basin and glass temperature.

The production of the distillate declines after 02:00 PM, although the temperature in the basin is relatively high, probably because of the lower solar intensity and cooling in the condensation zone.

Temperature between Insulation & Basin Water (°C) vs Time (Day 1)

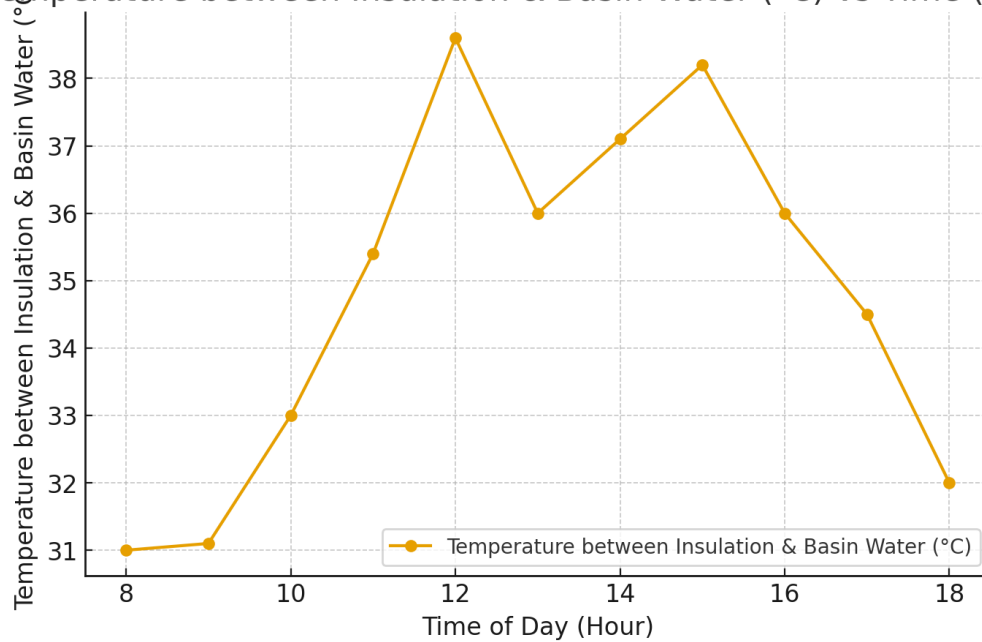

Figure 12: Temperature between insulation and Basin water vs time

This parameter begins approximately 31 °C in morning and increases to approximately 38.6 °C in 12:00 PM, and changes between 32 and 38 °C throughout the day as seen from Figure 14.

The difference illustrates the amount of heat lost via the insulation. Higher readings at noon indicate that more heat is trapped and that there is higher thermal gradient between the basin and the surroundings.

The experiment proves the correlation among solar radiation, ambient temperature, the temperature of the basin water, the temperature of the glass, and distillate output.

Solar Radiation: The solar input experienced a sharp increase in the morning with a peak of 950 W/m² at 11:00 AM and then decreased in the afternoon. At 12:00 PM (207 W/m²), it was observed to have suddenly reduced, which is probably due to momentary cloudiness or atmospheric fluctuation.

Ambient Temperature: During the day the ambient temperature rose steadily to a peak of 34 °C at 04:00 PM. This is natural increase in atmospheric temperature which is related to the decrease trend in the solar intensity but has lagged response related to the environment heat storage.

Basin Water Temperature: Basin water was very warm with a temperature of 33.4 °C at 8:00 AM and peaked at 66 °C at 2:00 PM. This shows that the solar energy absorption and retention in the basin is high and thus contributes to evaporation.

Glass Temperature: The glass cover had a similar trend to the basin water but it was relatively lower. It reached its highest temperature of 40.4 °C at 2:00 PM, thereby supporting condensation. The ratio of the temperature of the basin and the glass is critical to the performance of the process of condensing the vapor.

Distillate Collected: The highest yield of the distillate was recorded at 1:00 PM and was equal to 49.5 ml. High basin and glass temperatures at the peak production period were found to be more important than the peak solar radiation, thus proving the importance of thermal storage and temperature gradients in the distillate production process.

Temperature Insulation Basin Water: The difference varied between 31.0 °C in the early morning and 38.6 °C at noon. The high gradient is due to the heat losses in the insulation, the maximum loss being at midday when basin water temperatures were the highest.

4.1 Performance Evaluation of the Solar Still

Evaporative heat transfer

$$q_e = m_{ew} \times h_{fg} \quad (\text{V. Velmurugan and K. Srithar}) \text{ and } (\text{V. K. Mehta and H. Panchal}) \quad (3)$$

Useful Heat Absorbed by the glass is given by

$$Q_u = I(t_{total}) \times 3600 \times A_{glass} \quad (4)$$

Overall thermal efficiency of solar still is

$$\left[\frac{\Sigma M_{ew} \times h_{fg}}{\Sigma \{I(t) \times A_{glass} \times 3600\}} \right] \times 100\% \quad (\text{V. K. Mehta et al.}) \quad (5)$$

$$A_{glass} = L_{glass} \times w_{glass} \quad (6)$$

Where , m_{ew} is the daily productivity or distillate in kg

w_{glass} is the width of glass

h_{fg} is the latent heat of vaporization

L_{glass} is the length of glass

$I(t_{total})$ is the total solar radiation per day

A_{glass} is the area of glass

Table 10 shows the data obtained from the experimental tests were analyzed to evaluate the performance and behavior of the prototype under different operating conditions.

Table 10: Data Analysis Table

Time	Solar Radiation (W/m ²)	Ambient Temperature (°C)	Basin Temperature (°C)	Glass Temperature (°C)	Distillate Collected (ml)	Temperature between Insulation & Basin Water (°C)
08:00 AM	120	32.0	45.0	35.0	15	33.5
09:00 AM	229	41.5	53.2	40.8	20	49.3
10:00 AM	360	36.0	56.0	44.0	40	46.1
11:00 AM	301	38.9	53.2	39.7	65	48.3
12:00 PM	787	41.2	56.3	40.7	75	51.5
01:00 PM	375	37.9	53.6	39.1	65	48.6
02:00 PM	300	37.2	53.0	39.0	50	42.3
03:00 PM	158	35.9	47.3	37.4	30	37.8
04:00 PM	95	34.7	41.7	30.5	10	38.1
05:00 PM	70	34.0	40.0	29.0	8	35.5
06:00 PM	40	32.5	38.0	27.0	5	33.0

4.2 Heat Transfer Calculations and System Efficiency

Rate of Heat Transfer from Basin to Ambient

Using the formula for heat transfer from the basin liner to the ambient:

$$q_b = h_b \cdot A_b \cdot (T_b - T_a)$$

Where:

$$h_b = 0.893 \times 10^{-6} \text{ w/m}^2 \cdot \text{C}$$

$$A_b = 91 \text{ cm} \times 41 \text{ cm} = 0.3731 \text{ m}^2$$

At 11:00 AM

$$T_b = 48.5 \text{ } ^\circ\text{C}$$

$$T_a = 36.52 \text{ } ^\circ\text{C}$$

Rate of Heat Transfer from Basin to Ambient

$$q_b = 3.99 \times 10^{-3} \text{ w/m}^2$$

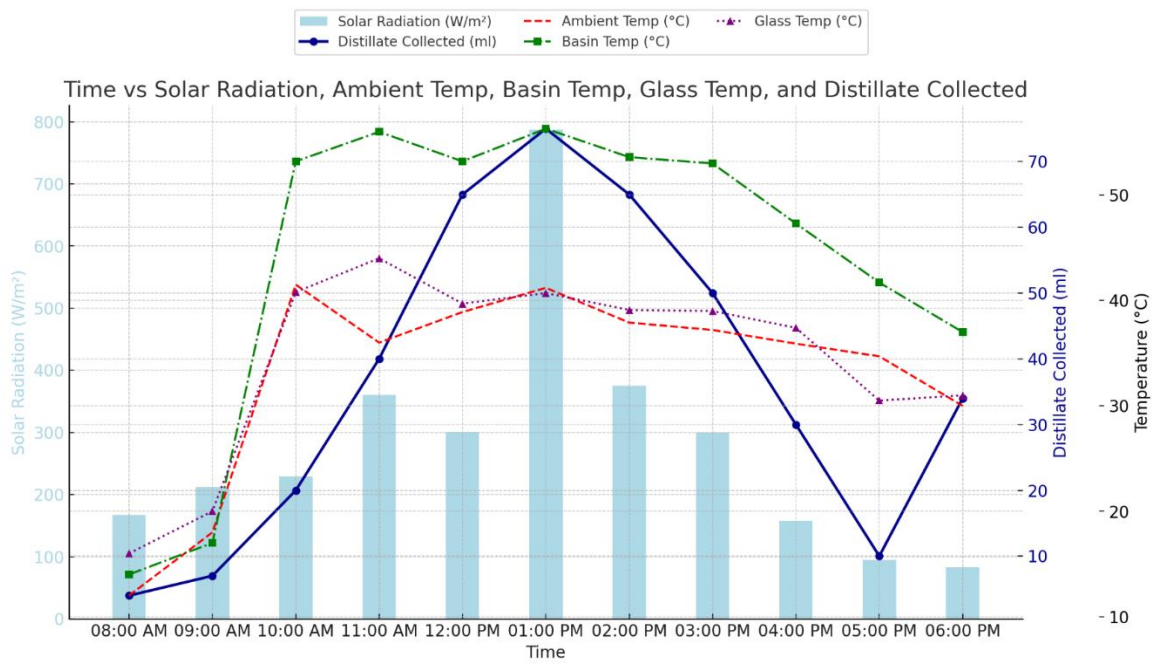

Figure 13 : Water Distillation with time

Table 11 presents the summary of results for all the data collected during the experiment period. It can be seen from the table below that, maximum distillate was collected on 02-09-2025 (Day 3) due to high radiation distribution of over the whole day. The thermal efficiency reaches maximum about 40% on the same day. For other days there might have been higher radiation but the intermittent cloud covering, and temperature change has not been so effective for solar still system, so the distillate collection was minimum. So, this concludes for better yield of fresh water from the solar still throughout the day, a bright sunny day with whole day sun is required. During cloudy days the distillate yield will be minimum due to intermittent sun and lower ambient temperature.

Table 11: Summary of results

Date	Total Solar Radiation (wh/m²)	Total Daily Production of fresh water (ml)	Evaporative Heat, $q_{e,w-g}$(MJ)	Efficiency, η (%)	Performance Note
31-08-2025	2559	155	0.35	8.0	Low performance due to clouds.
01-09-2025	4460	812	1.84	24.1	Good sunny day
02-09-2025	3831	1150	2.60	39.7	Best performance due to high yield.
03-09-2025	4434	510	1.15	15.2	High radiation but lower yield
04-09-2025	3285	331	0.75	13.3	Moderate day.

4.3 Comparison with Traditional Solar Stills

In comparison with the traditional single-slope solar stills, the test outcomes of the modified solar still indicate a higher thermal efficiency and higher rate of water production. Conventional solar stills, like those that utilize simple designs without additional improvements like insulation, black-painted basins, and solar collectors, tend to have lower efficiencies and yield less distilled water because of high heat loss and lower evaporation rates. According to

Tiwari et al. (2005), the efficiency of traditional solar stills ranges between 5% and 20%, which is quite low compared to the 8% to 39.7% efficiency recorded in this study. Similarly, the daily output of water in the conventional solar stills is generally lower due to lower efficiency of using heat as well as evaporation rates. The distillate yield was greater at a unit area in the modified solar still with the use of insulation and a galvanized iron basin in terms of water yield. The adoption of phase change material (PCMs) and installation of the solar collectors further increased the water generation, producing a more stable work all day long and less reliance on the maximum sun radiation. The performance of modified solar stills in generating water and efficiency was observed to be much better compared to the traditional designs. The thermal performance of the system and the daily productivity of the system were majorly enhanced as a result of insulation and solar collectors. The use of more sophisticated materials, including PCMs, further propelled the time span of its operation and the total efficiency, especially in areas where the sun did not shine all the time.

4.4 Potential for Large-Scale Implementation

There is also the prospect of mass-scale implementation of solar stills, particularly in arid and semi-arid areas where fresh water is limited and there is plenty of solar energy. But when small and domestic-scale units are to be scaled to large-scale desalination plants, we must take into consideration a few factors carefully. The productivity of solar stills is directly proportional to the quantity of the solar radiation and the size of the area covered by the unit. Since solar stills are usually quite large in size, the installations would require large portions of land to accommodate the large components. Multi-stage solar stills whereby multiple units are overlaid on one another to enhance the production of freshwater might be more appropriate in large-scale applications. Scalability of solar still technology is determined by the cost of materials, system efficiency, and installation and maintenance costs. In the large-scale implementation, the prices of tempered glass, insulation, and collectors have to be reduced by designing the materials and sourcing them locally. Solar stills on a large scale can be combined with the existing water supply structures, e.g., irrigation or municipality water supply. These systems can also help maximize dependence on fossil fuel or electric grids and, by utilizing solar energy, greatly increase the long-term sustainability and cost-effectiveness [23]

4.5 Challenges in Implementation

Although solar stills have benefits, various issues need to be handled before mass usage, especially when on a large scale. The water production rate is relatively low with solar stills, particularly the traditional systems, when compared to other desalination methods like reverse osmosis. This makes them less applicable to large-scale or decentralized use and more applicable to small-scale use or minor municipal or industrial use. The effectiveness of solar stills depends greatly on the local climatic factors such as solar radiation, ambient temperature, and humidity content. Solar stills might not work as well in areas that receive very low levels of solar energy or have high humidity, and some form of supplemental energy or adjustments to the design may be necessary. The components of a solar still, such as the transparent glass cover, might wear out over time as a result of being exposed to the sun and other environmental factors. The corrosion and fouling of the basin surface can also be experienced, which lowers the efficiency of the system. Long-term operation requires regular maintenance and usage of strong materials [25].

Chapter 5 Conclusion and Recommendations

The chapter provides the final conclusion of the research findings through the experimental assessment of the solar still system. It has also provided the constraints of the investigation, suggested future areas of research, and given practical suggestions on the implementation of solar still technology in a real-life scenario.

5.1 Summary of Findings

The current research was set out to develop, build, and test a single-slope solar still to desalinate salty water using the solar energy conversion. The findings of the experiment prove that the simple low-cost solar still can generate freshwater, and it can be used in different environmental conditions. The most important results are as follows. To begin with, the system was able to extract solar radiation and use it in desalinating saline water, thus transforming it into drinkable water. Its overall efficiency was determined to increase proportionally with incident solar radiation and ambient temperature, with the highest productivity at midday when the sun irradiance was maximal. Second, the mean daily freshwater yield was less than 2 L/day, and thermal efficiencies were 8-39.7%. This production was dependent on solar radiation, ambient temperature, and the inclination angle of the transparent cover. However, this system could produce freshwater with little energy expenditure, which highlights the possible efficacy of the system as a viable solution to a water-starved area. Third, later changes like insulation and a galvanized iron basin were made to enhance the thermal performance and increase the rate of evaporation. This was achieved by insulation to minimize heat losses and the galvanized basin to maximize solar uptake to increase water yields. Fourthly, weather conditions proved to be a decisive factor of performance. The presence of high solar irradiance and conducive ambient temperatures was vital in the production of greater productivities, and the presence of low irradiance or cloud cover yielded significantly lower efficiencies and lesser water yields. Lastly, improved properties, such as phase change materials (PCMs) and nanofluids, were found to be potentially useful in increasing thermal efficiency, but they were not included in the current research, so they should be considered in future studies.

5.2 Limitations of the Study

Although the study had promising outcomes, it had a number of limitations that limit the applicability and sustainability of the results. The first was that the test was conducted over a few days, and this discouraged long-term performance, durability, and sustained water production rates. Second, the efficiency of this system greatly depended on environmental factors like the amount of sunlight irradiating it, ambient temperature, and humidity. In times of low irradiance or cloudy days, the performance reduced largely, and there was a need to ensure that the weather conditions could be relied on. Thirdly, the deposition of salt deposits in the basin meant that frequent cleaning was necessary, thus hindering the smooth running of the production yield as well as augmenting the amount of maintenance required. Fourthly, the prototype was relatively small-scale and could be used by the household or a small community, it would need additional research on productivity improvement, land requirements, cost, and energy storage in the process of scaling up to large-scale or industrial application.

5.3 Future Research Directions

This research provided a basis to continue the research on the optimization and mass use of solar stills. The area of future studies must include the maximization of design to increase the rate of water production, reduce maintenance, and increase efficiency in various environmental conditions. This can include adopting multi-stage arrangements, solar concentrators and adoption of PCMs. Further reliability and scalability could be enhanced by hybridization of other renewed energy sources like photovoltaic panels or wind turbines. The use of more advanced materials, such as Nano coatings and nanofluids, and the use of graphene based absorbers should be explored to enhance the amount of heat transfer and the overall thermal efficiency. Long-term researches are necessary to check durability, maintenance demand and continuous water production, and to determine the environmental effects of salt disposal and to plan the sustainable salt-management measures. Lastly, large-scale desalination using solar still technology would entail a thorough economic and environmental feasibility analysis (cost benefit analysis, Life-cycle analysis and carbon-footprint analysis) to determine the viability of the technology [26].

5.4 Practical Recommendations for Implementation

Following the results of the current research, the following recommendations are offered concerning the effective application of the solar still technology in rural off-grid and disaster-

prone settings. In order to ensure the increased access to solar stills among the underserved communities, the use of affordable materials and the encouragement of local production is essential. Local procurement of parts saves production costs and increases the sustainability of the solar still consortium. Close training and building capacity of the communities are imperative necessary for the successful deployment of solar stills. It also requires workshops, step-by-steps manuals, and instantaneous technological support so that individuals do not need to contact an expert constantly to maintain their installations. Engaging the community is important, and it is impossible to place a solar still in a village and hope that it will be utilized and maintained. Solar stills can also be co-located with existing in-place water management systems, including rainwater harvesting facilities and water storage tanks which will maintain a continuous supply of drinking water flowing. Such integration will increase the duration of the entire process and reduce the additional water requirements. This type of integration makes the system more sustainable and reduces its reliance on external water sources. Moreover, solar stills must be scalable, with larger projects like community or industry-scale desalination being able to use the stills. The technology is easily adapted to various scale of operation using modular and expandable structures. A standardized monitoring regime is necessary to evaluate the performance of solar stills with time. The basin, glass cover and storage tanks are checked regularly to make sure that the system is efficient and effective by training the local communities to do routine maintenance, including cleaning of salt deposits, downtime is reduced. Lastly governments have a central influence in creating an environment to support the adoption of solar stills through incentive and subsidy offerings and funding of research. Policies formulated by the government to create an enabling setting of renewable energy technologies will make sure that solar stills are part of national plans to reduce the problem of water scarcity.

References

1. Rosegrant, M. W., & Cai, X. (2002). Global water demand and supply projections. *Water International*, 27(2), 170–182. <https://doi.org/10.1080/02508060208686990>
2. Pourkiaei, S. M., Ahmadi, M. H., Ghazvini, M., Moosavi, S., Pourfayaz, F., Kumar, R., & Chen, L. (2021). Status of direct and indirect solar desalination methods: comprehensive review. *The European Physical Journal Plus*, 136(5). <https://doi.org/10.1140/epjp/s13360-021-01560-3>
3. Khalid, S., Shahid, M., Natasha, N., Bibi, I., Sarwar, T., Shah, A. H., & Niazi, N. K. (2018). A Review of Environmental Contamination and Health Risk Assessment of Wastewater Use for Crop Irrigation with a Focus on Low and High-Income Countries. *International Journal of Environmental Research and Public Health*, 15(5), 895. <https://doi.org/10.3390/ijerph15050895>
4. Kober, T., Schiffer, H., Densing, M., & Panos, E. (2020). Global energy perspectives to 2060 – WEC’s World Energy Scenarios 2019. *Energy Strategy Reviews*, 31, 100523. <https://doi.org/10.1016/j.esr.2020.100523>
5. Reif, J. H., & Alhalabi, W. (2015). Solar-thermal powered desalination: Its significant challenges and potential. *Renewable and Sustainable Energy Reviews*, 48, 152–165. <https://doi.org/10.1016/j.rser.2015.03.065>
6. Chow, V. T. (1979). Water as a world resource. *Water International*, 4(1), 3–24. <https://doi.org/10.1080/02508067908685798>
7. Fessahaye, A. K., Xie, Y., Hu, Y., Dai, G., Zheng, H., & Teng, W. (2025). Groundwater Over-Extraction: Comprehensive Review of socio-economic impacts and pathways to Sustainable management. *European Journal of Theoretical and Applied Sciences*, 3(2), 190–211. [https://doi.org/10.59324/ejtas.2025.3\(2\).15](https://doi.org/10.59324/ejtas.2025.3(2).15)
8. Sarker, B., Keya, K. N., Mahir, F. I., Nahiun, K. M., Shahida, S., & Khan, R. A. (2021). Surface and Ground Water Pollution: Causes and Effects of Urbanization and Industrialization in South Asia. *Scientific Review*, 73, 32–41. <https://doi.org/10.32861/sr.73.32.41>
9. Thi, H. T. D., & Tóth, A. J. (2023). Investigation of carbon footprints of three desalination technologies: reverse osmosis (RO), Multi-Stage Flash Distillation (MSF) and Multi-Effect Distillation (MED). *Periodica Polytechnica Chemical Engineering*, 67(1), 41–48. <https://doi.org/10.3311/ppch.20901>

10. Cath, T., Childress, A., & Elimelech, M. (2006). Forward osmosis: Principles, applications, and recent developments. *Journal of Membrane Science*, 281(1–2), 70–87. <https://doi.org/10.1016/j.memsci.2006.05.048>
11. Gude, V. G., Nirmalakhandan, N., & Deng, S. (2010). Renewable and sustainable approaches for desalination. *Renewable and Sustainable Energy Reviews*, 14(9), 2641–2654. <https://doi.org/10.1016/j.rser.2010.06.008>
12. Shatat, M., Worall, M., & Riffat, S. (2013). Opportunities for solar water desalination worldwide: Review. *Sustainable Cities and Society*, 9, 67–80. <https://doi.org/10.1016/j.scs.2013.03.004>
13. Delgado, W. R., Beach, T., & Luzzadder-Beach, S. (2020). Solar desalination: Cases, synthesis, and challenges. *Wiley Interdisciplinary Reviews Water*, 7(3). <https://doi.org/10.1002/wat2.1434>
14. Abdallah, S., Badran, O., & Abu-Khader, M. M. (2007). Performance evaluation of a modified design of a single slope solar still. *Desalination*, 219(1–3), 222–230. <https://doi.org/10.1016/j.desal.2007.05.015>
15. Badran, O. (2007). Experimental study of the enhancement parameters on a single slope solar still productivity. *Desalination*, 209(1–3), 136–143. <https://doi.org/10.1016/j.desal.2007.04.022>
16. Badran, O. O., & Abu-Khader, M. M. (2006). Evaluating thermal performance of a single slope solar still. *Heat and Mass Transfer*, 43(10), 985–995. <https://doi.org/10.1007/s00231-006-0180-0>
17. Tony, M. A., & Nabwey, H. A. (2024). Recent advances in solar still technology for solar water desalination. *Applied Water Science*, 14(7). <https://doi.org/10.1007/s13201-024-02188-1>
18. Chauhan, V. K., Shukla, S. K., Tirkey, J. V., & Rathore, P. K. S. (2020). A comprehensive review of direct solar desalination techniques and its advancements. *Journal of Cleaner Production*, 284, 124719. <https://doi.org/10.1016/j.jclepro.2020.124719>
19. Sahu, R., & Tiwari, A. C. (2024). Performance enhancement of single slope solar still using nanofluids at different water depth. *Desalination and Water Treatment*, 317, 100046. <https://doi.org/10.1016/j.dwt.2024.100046>
20. Gnanaraj, S. J. P., & Velmurugan, V. (2019). An experimental study on the efficacy of modifications in enhancing the performance of single basin double slope solar still. *Desalination*, 467, 12–28. <https://doi.org/10.1016/j.desal.2019.05.015>

21. Sajid, I., Sarwar, A., Tariq, M., Bakhsh, F. I., Ahmad, S., & Mohamed, A. S. N. (2025). An efficient tangent search based power harnessing algorithm for photovoltaic energy generation system. *Computers & Electrical Engineering*, *123*, 110118. <https://doi.org/10.1016/j.compeleceng.2025.110118>
22. Sodha, Nayak, J., Singh, U., & Tiwari, G. (1981). Thermal performance of a solar still. *Journal of Energy*, *5*(6), 331–336. <https://doi.org/10.2514/3.48038>
23. Geete, A., Kharve, D., Patel, H., Karma, H., Prajapati, A., & Sharma, S. (2020). Comparative exergy and exergy efficiency analyses of fabricated single and double slope solar still plants at Indore: case study. *SN Applied Sciences*, *2*(5). <https://doi.org/10.1007/s42452-020-2763-7>
24. Geete, A., Kharve, D., Patel, H., Karma, H., Prajapati, A., & Sharma, S. (2020). Comparative exergy and exergy efficiency analyses of fabricated single and double slope solar still plants at Indore: case study. *SN Applied Sciences*, *2*(5). <https://doi.org/10.1007/s42452-020-2763-7>
25. Essa, F. A., Abdullah, A., Majdi, H. S., Basem, A., Dhahad, H. A., Omara, Z. M., Mohammed, S. A., Alawee, W. H., Ezzi, A. A., & Yusaf, T. (2022). Parameters Affecting the efficiency of Solar Stills—Recent Review. *Sustainability*, *14*(17), 10668. <https://doi.org/10.3390/su141710668>
26. Sharshir, S., Yang, N., Peng, G., & Kabeel, A. (2016). Factors affecting solar stills productivity and improvement techniques: A detailed review. *Applied Thermal Engineering*, *100*, 267–284. <https://doi.org/10.1016/j.applthermaleng.2015.11.041>